

- EN** Quick Guide
- FI** Pikaohje
- SV** Snabbhandledning
- DN** Lynvejledning
- NO** Hurtigveiledning
- EL** Γρήγορος Οδηγός

iCare HOME2

Quick Guide

icare

iCare HOME2
Quick Guide



Read this Quick Guide and watch the HOME2 user instructions video before using the tonometer. Follow the instructions step by step.



For safety information, read Chapter 1 in the Instruction Manual before using the tonometer.

If you need help in using the iCare HOME2 tonometer, contact your healthcare professional.



PRECAUTION! Before taking measurements, update the tonometer's time to your local time manually from the tonometer's settings or automatically by connecting the tonometer to the iCare PATIENT2 application or to the iCare EXPORT software.



English

Step

Page

1	Inserting the batteries	5
2	Inserting the probe	6
3	Switching on	8
4	Correct measurement position	9
5	Adjusting the supports and positioning the tonometer	10
6	Measuring eye pressure	12
7	Measuring eye pressure in the supine position	14
8	Troubleshooting	16
9	Switching off the tonometer and disposing of the probe	18

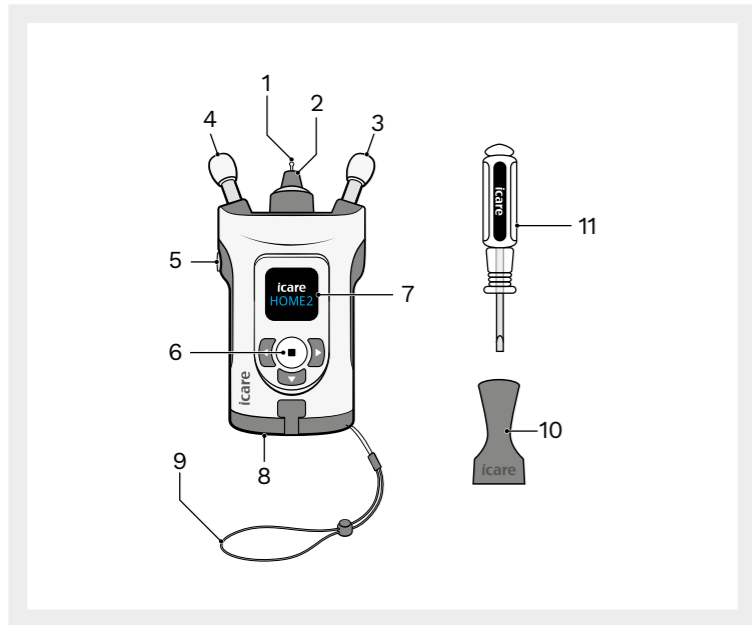

- 1 Probe
- 2 Probe base
- 3 Cheek support
- 4 Forehead support
- 5 Measure button
- 6 Select button
- 7 Display
- 8 Battery cover
- 9 Wrist strap
- 10 Probe applicator
- 11 Screwdriver

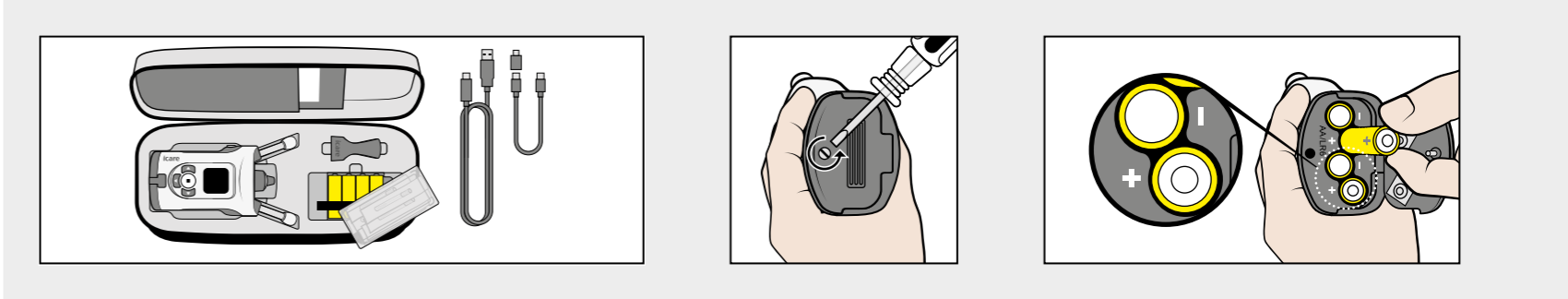

The batteries are in the tonometer carrying case under the box of probes.

Open the battery cover with the screwdriver.

Insert the batteries, and close the cover.

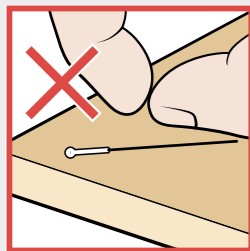

Do not use a probe if it has touched your hand, a table, or other nonsterile surface.

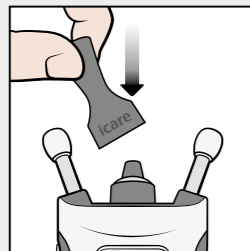

Place the probe applicator over the probe base.

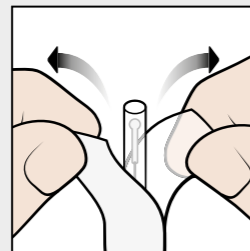

Open the packaging.

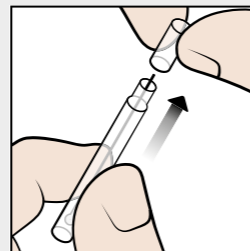

Remove the cap.



WARNING! To prevent contamination, keep unused probes in their box. Do not touch a bare probe. Do not use a probe if it touches a non-sterile surface such as a table or a floor.

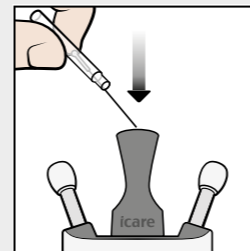

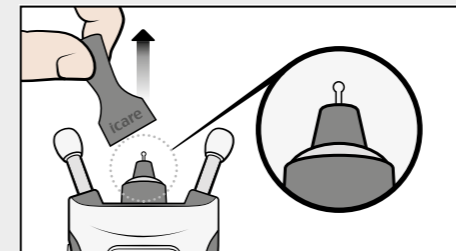

Drop the probe from the container to the probe applicator.

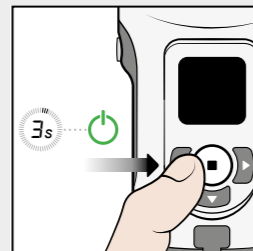
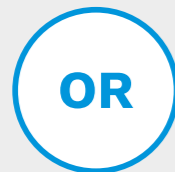
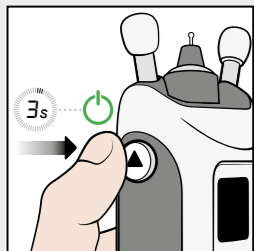

Remove the probe applicator.



Press down  until you hear a beep. The text “Start” is shown on the display.

Alternatively, press down  until you hear a beep. Then press  again to enter the measurement mode. The text “Start” is shown on the display.

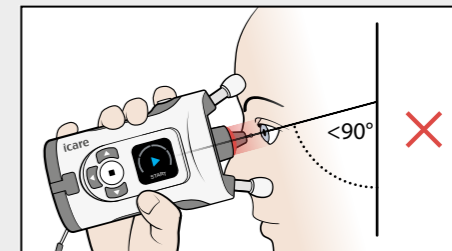
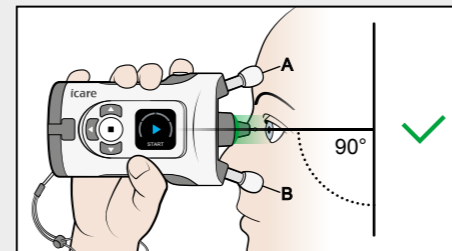
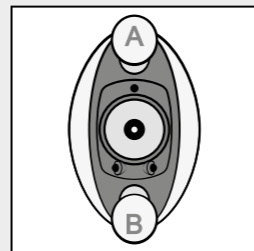

The forehead support A rests on your forehead and the cheek support B rests on your cheek.

Look straight ahead and the tonometer is at a 90-degree angle to your face. The probe is about 5 mm from your eye and points perpendicularly to the center of your eye.

If you see a red light in the probe base, the tonometer is tilted too much downwards. You should straighten your posture and lift your chin.

Positioning the tonometer is instructed in the following section.

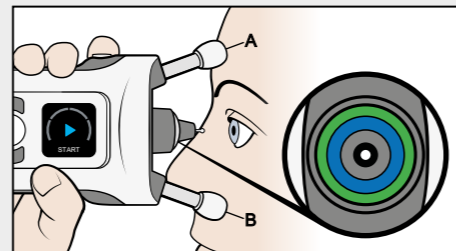
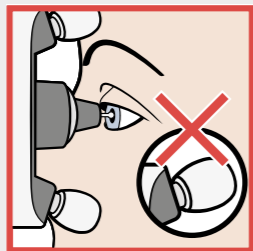
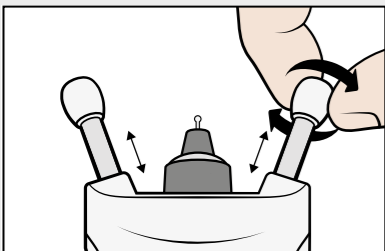

Before the measurement, adjust the forehead and cheek supports to the correct length. Start with the supports at the maximum length.

Shorten the supports only two clicks at a time to prevent the tonometer from getting too close to your eye.

Place the tonometer against your face and look into the probe base. The probe points perpendicularly to the center of your eye when the blue and green rings in the probe base are symmetrical.



WARNING! Only the probe should touch the eye. Do not touch your eye with any other parts of the tonometer. Do not poke your eye with the tonometer.

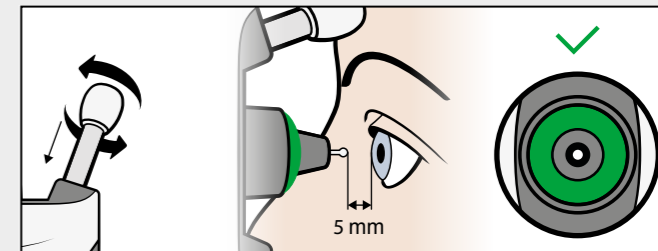
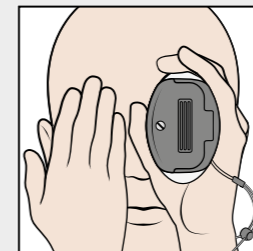
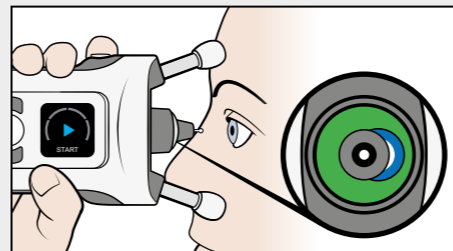

If the rings are not symmetrical, the probe does not point perpendicularly to the center of your eye. Correct the position of the tonometer.

Keep both eyes open. Covering the eye not being tested may help you see the rings more clearly.

Shorten the supports by rotating them clockwise two clicks at a time until you only see a symmetrical green ring. The tonometer is now at the correct distance from your eye.

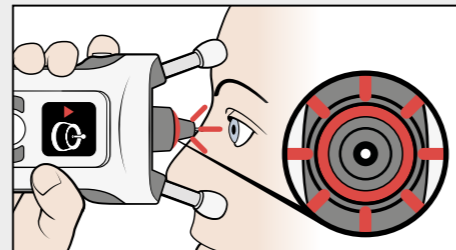
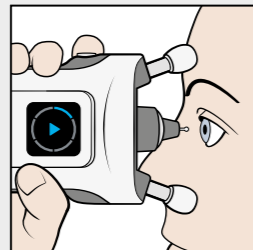
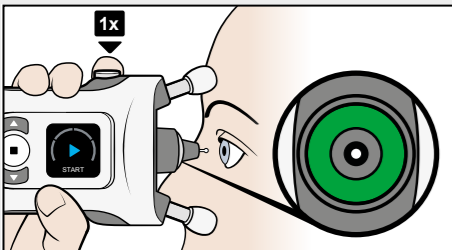

Start the measurement when you see only a symmetrical green ring. Press the Measure button  once. The probe gently touches your eye.

A single beep indicates a successful measurement. Continue taking measurements until you hear a long beep and the light in the probe base turns off.

If the probe base flashes red and you hear multiple beeps, the measurement was not successful. See **Troubleshooting** on page 16.

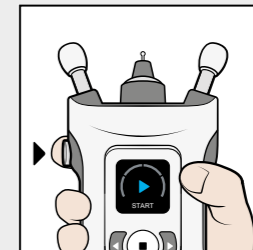
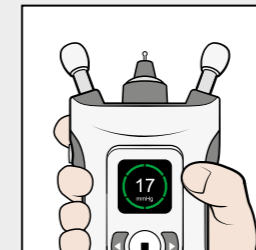
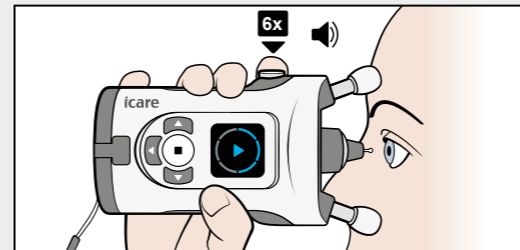

A measurement sequence consists of six measurements.

Tip: You can also take the measurement sequence by pressing and holding the Measure button  down until all six measurements have been taken.

When all six measurements have been successfully taken, you hear a longer beep, the light in the probe base turns off, and you see the result on the display.

Press the Measure button  once and repeat the measurement on your other eye.

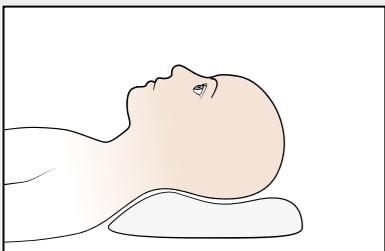

Before measuring, lie down for a moment.

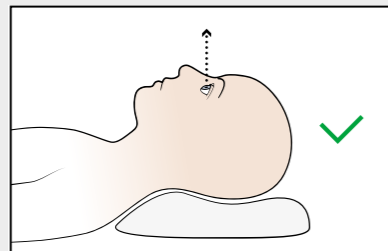

Take a comfortable position on your back with a pillow behind your neck. Look straight ahead.

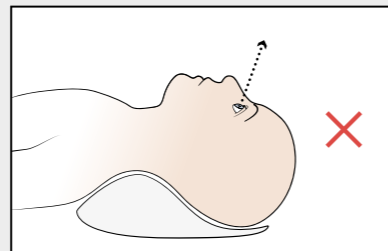

Avoid bending your head backwards.

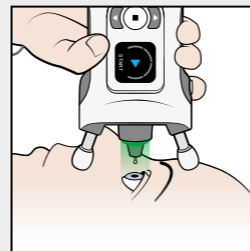

Place the tonometer at a 90 degrees angle on your face and take the measurement as previously instructed.

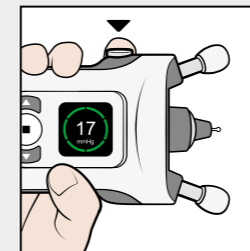



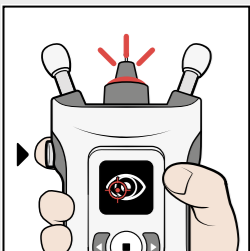









After a successful measurement, press the Measure button  once and repeat the measurement on your other eye.



If an error occurs, the probe base flashes red. The display and sounds indicate the source of the error.

Look at the display, press the Measure button  once, make the necessary corrections, and repeat the measurement.

Icon	Display text	Sound	Problem	Solution
	TOO FAR	3 long 	The probe is too far away from the eye.	Press the Measure button  once to acknowledge the error. Shorten the forehead and cheek supports.
	TOO NEAR	5 short 	The probe is too close to the eye.	Press the Measure button  once to acknowledge the error. Lengthen the forehead and cheek supports.
	INCORRECT ALIGNMENT	2 short 	The probe was not perpendicular to the cornea or the probe hit an eyelid or eyelashes.	Press the Measure button  once to acknowledge the error. Position the tonometer so that the probe points perpendicularly to the center of your eye. Keep your eye properly open.
	REPEAT	2 short 	There was a problem with the movement of the probe.	Press the Measure button  once to acknowledge the error. Repeat the measurement.

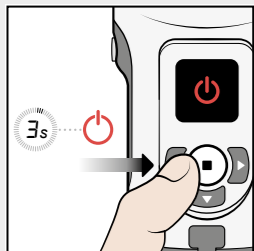

Press and hold the Select button  until you hear 3 beeps and the display switches off.

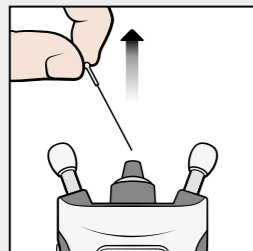

Remove the probe and place it back into the probe container.



Dispose of the probe and the container in a mixed waste bin.

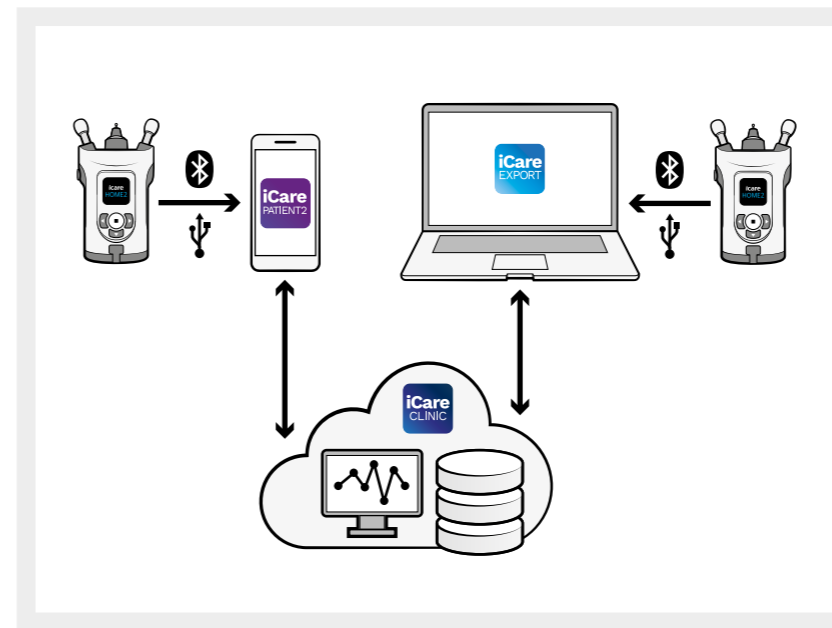

Now you can transfer your measurement results to your doctor's iCare CLINIC or to your private account in the iCare Cloud by using the iCare PATIENT2 app on your mobile device or the iCare EXPORT software on your computer.



Lue tämä pikaohje ja katso HOME2-käyttöohjevideo ennen silmänpainemittarin käyttöä. Noudata ohjeita vaiheittain.



Lue käyttöohjeen luvussa 1 olevat turvallisuustiedot ennen silmänpainemittarin käyttöä.

Jos tarvitset apua iCare HOME2 -silmänpainemittarin käyttämisessä, ota yhteyttä terveydenhuollon ammattilaiseen.



HUOM! Ennen mittauksien tekemistä, päivitä silmänpainemittarin aika paikalliseen aikaan joko manuaalisesti silmänpainemittarin asetuksista tai automaattisesti yhdistämällä silmänpainemittari iCare PATIENT2 -sovellukseen tai iCare EXPORT -ohjelmistoon.



Suomi

Vaihe

Sivu

1	Paristojen asettaminen paikoilleen	23
2	Anturin asettaminen paikalleen	24
3	Käynnistäminen	26
4	Oikea mittausasento	27
5	Tukien säätäminen ja silmänpainemittarin asemointi	28
6	Silmänpaineen mittaaminen	30
7	Silmänpaineen mittaaminen makuuasennossa	32
8	Toiminta virhetilanteissa	34
9	Silmänpainemittarin sammuttaminen ja anturin hävittäminen	36

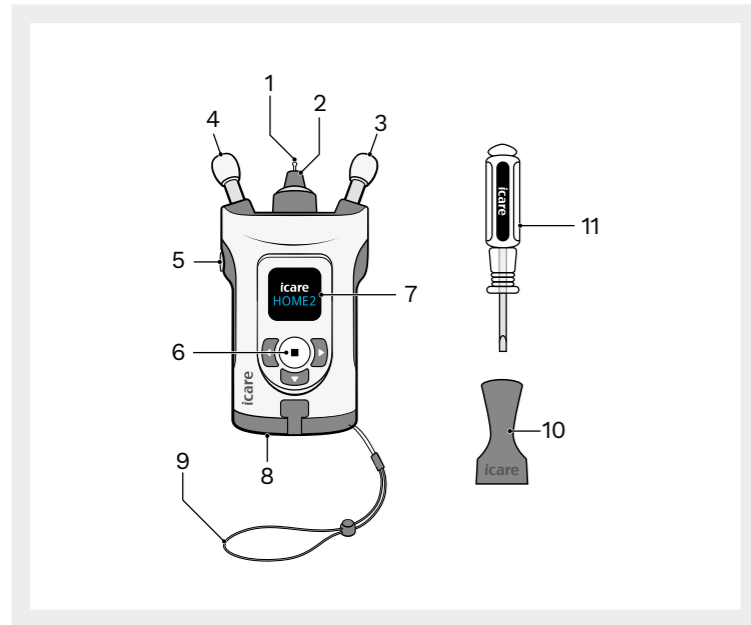

- 1 Anturipesä
- 2 Anturin kanta
- 3 Poskituki
- 4 Otsatuki
- 5 Mittauspainike
- 6 Valintapainike
- 7 Näyttö
- 8 Paristolokeron kansi
- 9 Rannehihna
- 10 Anturin asetin
- 11 Ruuvimeisseli

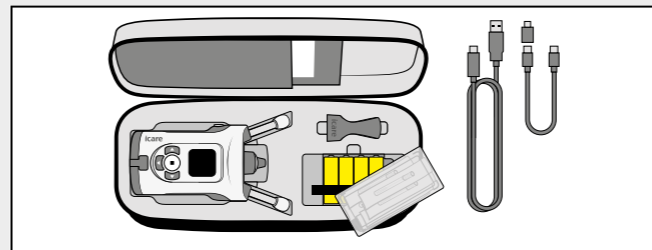

Paristot ovat silmänpainemittarin kantokotelossa anturirasian alla.

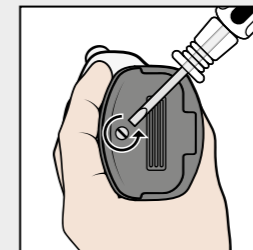

Avaa paristolokeron kansi ruuvimeisselillä.

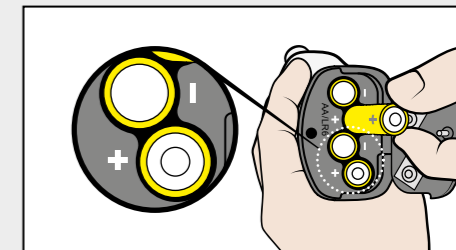

Aseta paristot paikoilleen ja sulje kansi.

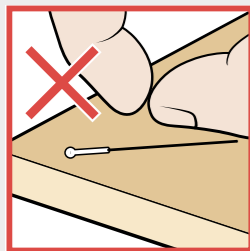

Älä käytä anturia, jos se on koskettanut kättäsi, pöytää tai muuta sterilointota pintaa.

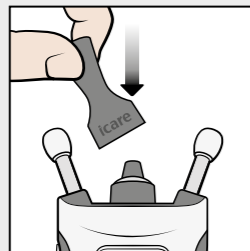

Aseta anturin asetin anturipesän päälle.

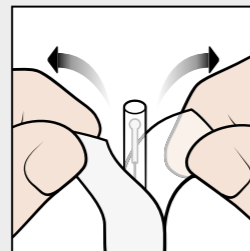

Avaa pakkaus.

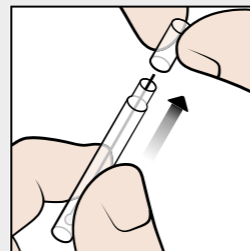

Poista korkki.



VAROITUS! Kontaminaation estämiseksi säilytä käyttämättömät anturit laatikossaan. Älä koske paljasta anturia. Älä käytä anturia, jos se koskettaa sterilointota pintaa, kuten esimerkiksi pöytää tai lattiaa.

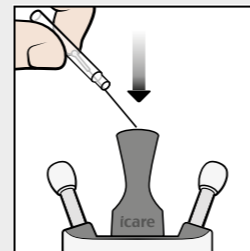

Pudota anturi anturin asettimeen.

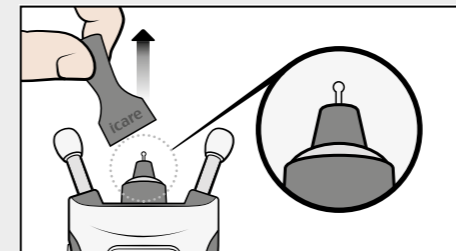

Poista anturin asetin.

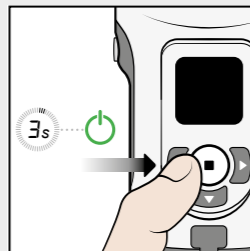
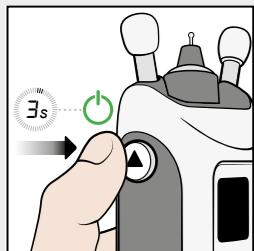

Pidä ▶-painiketta painettuna, kunnes kuulet äänimerkin. Aloita-teksti näkyy näytöllä.

Vaihtoehtoisesti voit pitää ◻-painikkeen painettuna, kunnes kuulet äänimerkin. Siirry sitten mittaustilaan painamalla ◻-painiketta uudelleen. Aloita-teksti näkyy näytöllä.

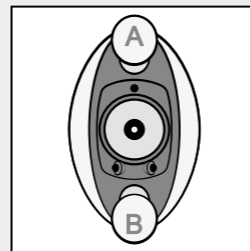

Otsatuki A lepää otsallasi ja poskituki B lepää poskellasi.

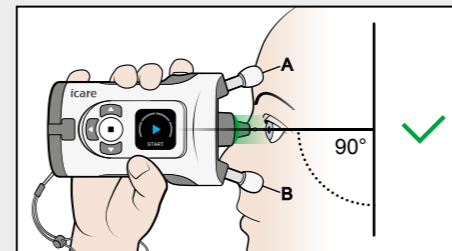

Katso suoraan eteenpäin. Silmänpainemittari on 90 asteen kulmassa kasvoihisi nähden. Anturi on noin 5 mm päässä silmästäsi ja osoittaa kohtisuoraan silmän keskelle.

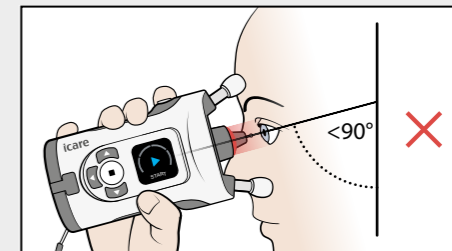

Jos anturipesässä näkyy punainen valo, silmänpainemittari on kallistunut liikaa alaspäin. Suorista ryhtisi ja nosta leukaasi.

Silmänpainemittarin aseointi kuvataan seuraavassa luvussa.

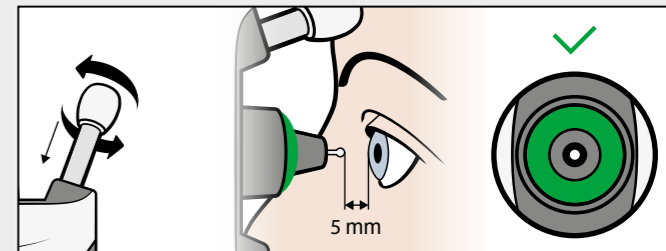
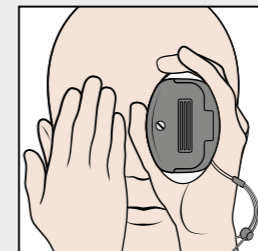
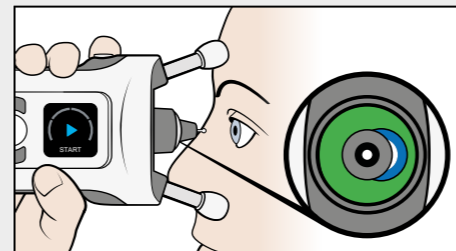
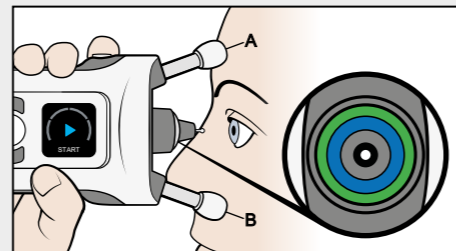
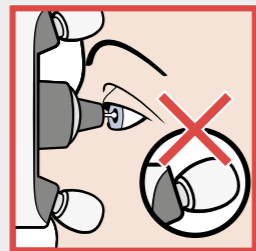
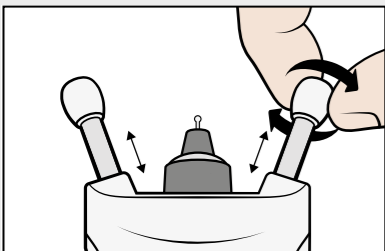

Ennen mittausta säädä otsa- ja poskituet oikeaan pituuteen. Aloita tukien maksimipituudesta.

Lyhennä tukia vain kaksi napsautusta kerrallaan, jotta silmänpainemittari ei tule liian lähelle silmääsi.

Aseta silmänpainemittari kasvoja vasten ja katso anturipesään kantaan. Anturi osoittaa kohtisuoraan silmän keskelle, kun anturipesän sininen ja vihreä rengas ovat symmetriset.

Jos renkaat ovat epäsymmetriset, anturi ei osoita kohtisuoraan keskelle silmää. Korjaa silmänpainemittarin asento.

Pidä molemmat silmät auki. Toisen silmän peittäminen voi auttaa näkemään renkaat paremmin.

Lyhennä tukia kiertämällä niitä myötäpäivään kaksi napsautusta kerrallaan, kunnes näet vain symmetrisen vihreän renkaan. Silmänpainemittari on nyt oikealla etäisyydellä silmästäsi.



VAROITUS! Vain anturin pitäisi koskettaa silmää. Älä tökkää silmääsi muilla silmänpainemittarin osilla. Älä töki silmääsi silmänpainemittarilla.

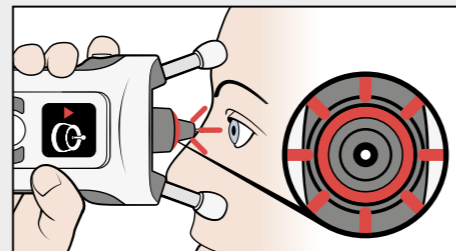
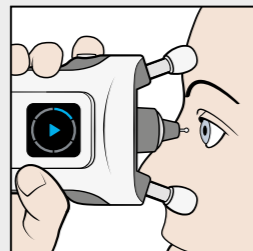
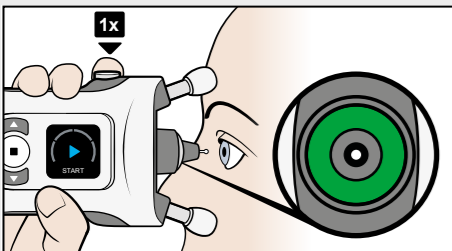

Aloita mittaus, kun näet vain symmetrisen vihreän renkaan. Paina mittauspainiketta  kerran. Anturi koskettaa kevyesti silmääsi.

Yksi äänimerkki kertoo, että mittaus onnistui. Jatka mittausten tekemistä, kunnes kuulet pitkän äänimerkin ja anturin kannassa anturipesän valo sammuu.

Jos anturipesä kanta vilkkuu punaisena ja kuulet useita äänimerkkejä, mittaus ei onnistunut. Lisätietoja on kohdassa **Toiminta virhetilanteissa** sivulla 34.

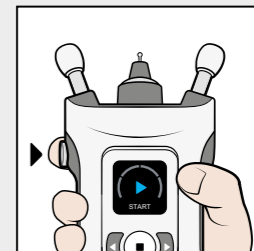
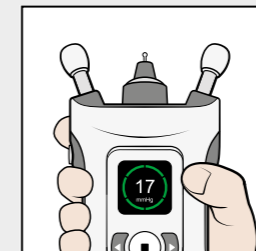
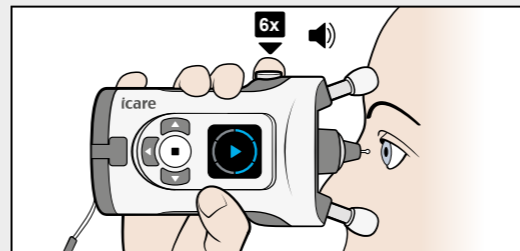

Mittaussarja koostuu kuudesta mittauksesta.

Vinkki: Voit myös ottaa mittaussarjan pitämällä mittauspainikkeen  painettuna siihen asti, kunnes kuusi mittausta on tehty.

Kun kaikki kuusi mittausta on tehty onnistuneesti, kuulet pidemmän äänimerkin, anturipesän kannan valo sammuu ja näet tuloksen näytöllä.

Paina mittauspainiketta  kerran ja toista mittaus toisella silmällä.

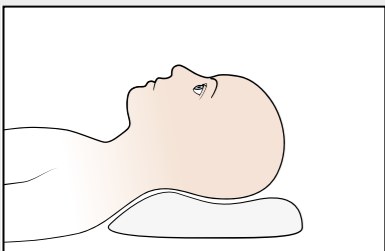

Käy makuulle hetkeksi ennen mittausta.

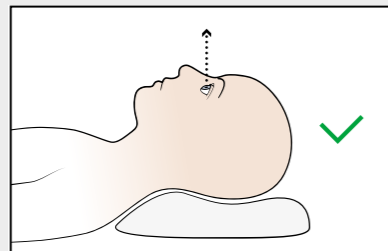

Ota mukava asento selinmakuulla ja aseta tyyny niskan taakse. Katso suoraan eteenpäin.

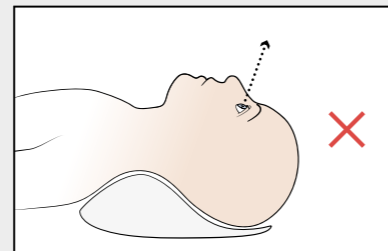

Vältä pään taivuttamista taaksepäin.

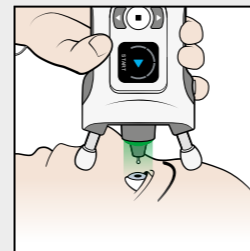

Aseta silmänpainemittari 90 asteen kulmaan kasvoihisi nähden ja tee mittaus edellä kuvatulla tavalla.

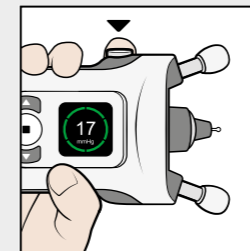



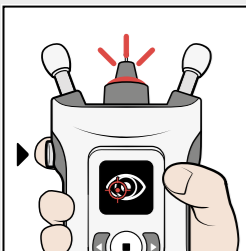





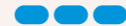

Paina mittauspainiketta  kerran onnistuneen mittauksen jälkeen ja toista mittausta toisella silmällä.



Anturipesä kanta vilkkuu punaisena, jos tapahtuu virhe. Näyttö ja äänet ilmaisevat virheen lähteen.

Katso näyttöä, paina mittauspainiketta  kerran, tee tarvittavat korjaukset ja toista mittaus.

Kuvake	Näyttöteksti	Ääni	Ongelma	Ratkaisu
	KAUKANA	3 pitkää 	Anturi on liian kaukana silmästä.	Kuittaa virhe painamalla mittauspainiketta  kerran. Lyhennä otsa- ja poskitukia.
	LÄHELLÄ	5 lyhyttä 	Anturi on liian lähellä silmää.	Kuittaa virhe painamalla mittauspainiketta  kerran. Pidennä otsa- ja poskitukia.
	VIRHEELLINEN KOHDISTUS	2 lyhyttä 	Anturi ei ollut kohtisuorassa silmään nähden tai anturi osui silmäluomeen tai silmäripsiin.	Kuittaa virhe painamalla mittauspainiketta  kerran. Aseta silmänpainemittari siten, että anturi osoittaa kohtisuoraan keskelle silmää. Pidä silmäsi kunnolla auki.
	TOISTA	2 lyhyttä 	Ongelma anturin liikkumisen kanssa.	Kuittaa virhe painamalla mittauspainiketta  kerran. Toista mittaus.

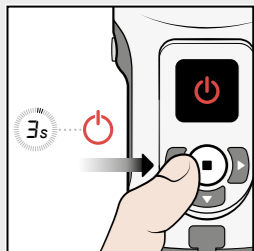

Pidä valintapainiketta  painettuna, kunnes kuulet kolme äänimerkkiä ja näyttö sammuu.

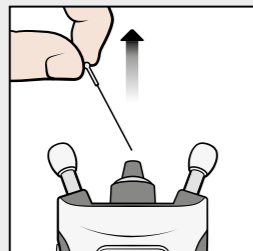

Poista anturi ja aseta se takaisin anturiputkilo.



Hävitä anturi laittamalla se sakajäteastiaan.

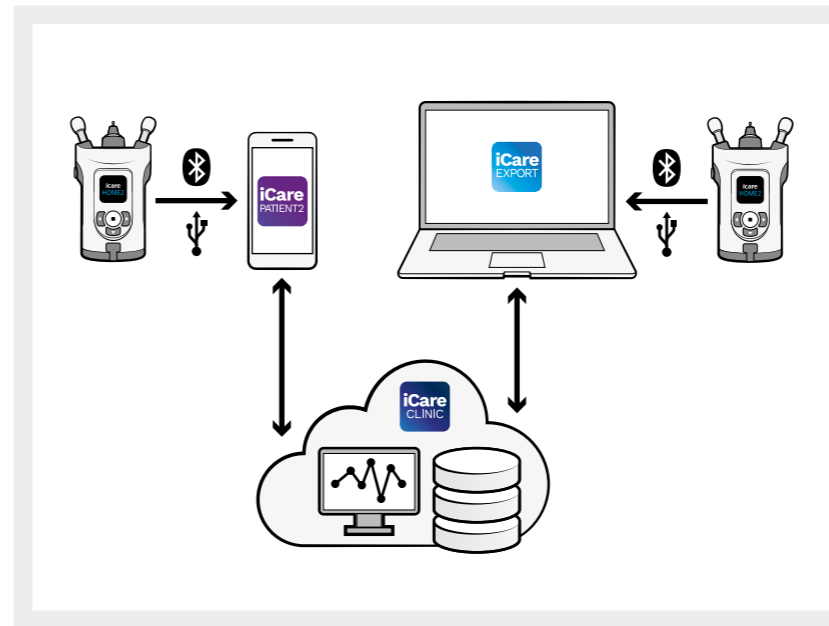

Nyt voit siirtää mittaustuloksesi lääkärisi iCare CLINIC -tilille tai yksityiselle iCare CLOUD -tilillesi käyttämällä mobiililaitteellasi iCare PATIENT2 -sovellusta tai tietokoneesi iCare EXPORT -ohjelmistoa.



Läs snabbhandledningen och titta på instruktionsvideon för HOME2 innan du använder tonometern. Följ instruktionerna steg för steg.



För säkerhetsinformation, läs kapitel 1 i användarhandboken innan du använder tonometern.

Om du behöver hjälp med att använda din tonometer iCare HOME2, kontakta sjukvårdspersonal.



FÖRSIKTIGHET! Innan du börjar mäta, ställ in den lokala tiden på tonometern, antingen manuellt i tonometerns inställningar eller automatiskt genom att ansluta tonometern till appen iCare PATIENT2 eller programmet iCare EXPORT.



Svenska

Steg

Sida

1	Sätta i batterier	41
2	Sätta i sonden	42
3	Aktivering	44
4	Korrekt mätposition	45
5	Ställa in stöden och rikta in tonometern	46
6	Mäta ögontrycket	48
7	Mäta ögontrycket liggande	50
8	Felsökning	52
9	Stänga av tonometern och kassera sonden	54

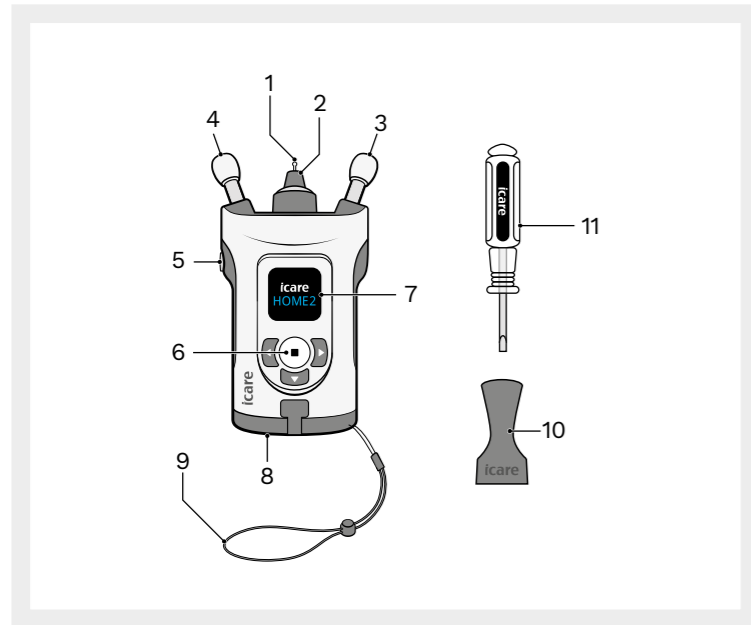

- 1 Sond
- 2 Sondbas
- 3 Kindstöd
- 4 Pannstöd
- 5 Mät-knapp
- 6 Välj-knapp
- 7 Skärm
- 8 Batterilucka
- 9 Handledsrem
- 10 Sondapplikator
- 11 Skruvmejsel

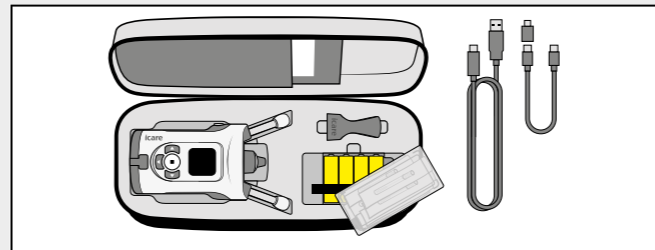

Batterierna ligger i tonometerens bärväska under asken med sonder.

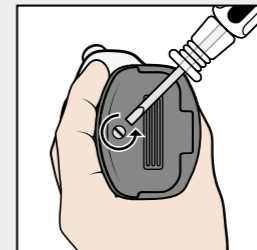

Öppna batteriluckan med skruvmejseln.

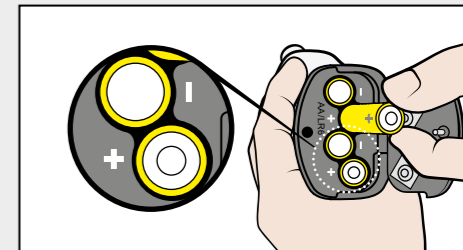

Sätt i batterierna och stäng luckan.

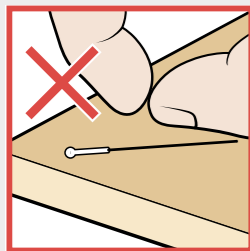

Använd inte en sond om den har vidrört din hand, ett bord eller andra icke-desinficerade ytor.

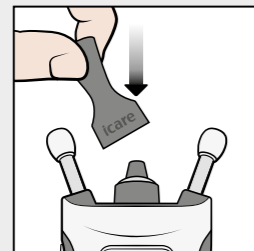

Placera sondapplikatorn på sondbasen.

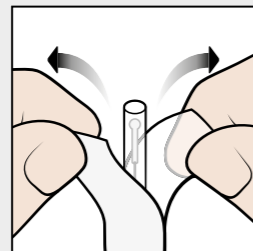

Öppna förpackningen.

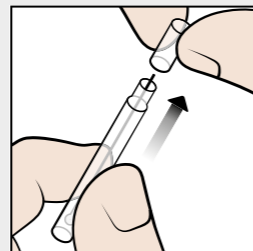

Ta av locket.



VARNING! Låt oanvända sonder ligga kvar i asken för att undvika nedsmutsning. Rör aldrig vid en bar sond. Använd inte en sond om den kommit i kontakt med en icke-desinficerad yta, t.ex. bordet eller golvet.

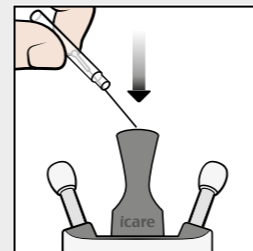

Släpp ner sonden ur behållaren in i sondapplikatorn.

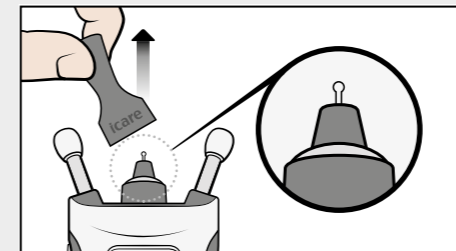

Avlägsna sondapplikatorn.

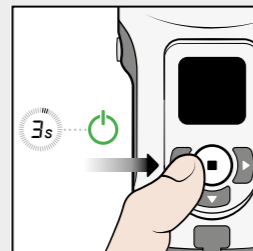
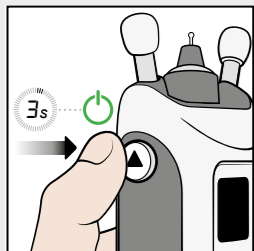

Tryck ner ▶ tills du hör ett pip ljud. Texten "Start" visas på skärmen.

Du kan också trycka ner ■ tills du hör ett pip ljud. Tryck sedan på ◻ för att starta mätläget. Texten "Start" visas på skärmen.

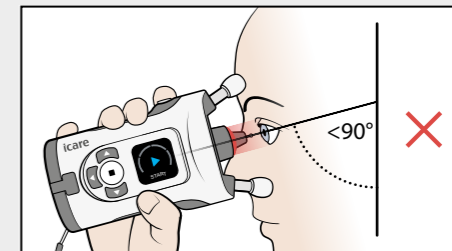
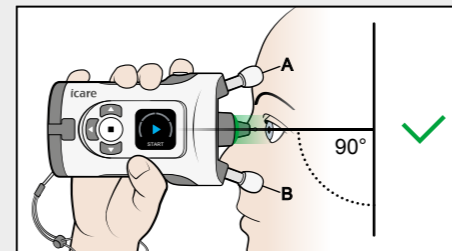
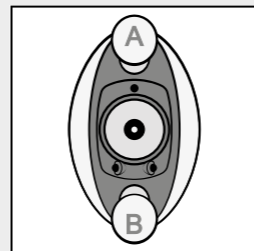

Pannstödet A ska vila mot pannan och kindstödet B ska vila mot kinden.

Tonometern ska hållas i 90 graders vinkel mot ansiktet när du tittar rakt fram. Sonden ska vara ungefär 5 mm från ögat och peka vinkelrätt mot mitten av ögat.

Om du ser ett rött ljus i sondbasen betyder det att tonometern lutar för mycket nedåt. Räta ut din hållning och lyft hakan.

I nästa avsnitt får du se hur du lär dig att placera tonometern i rätt position.

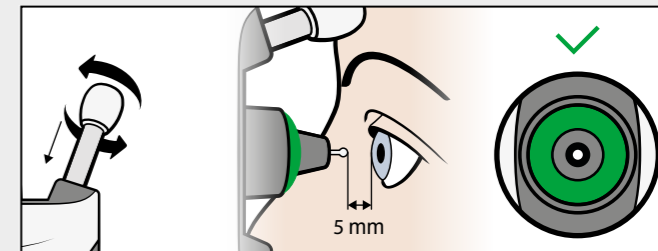
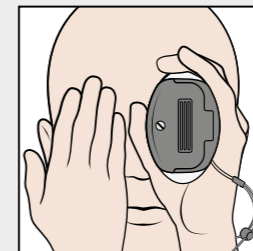
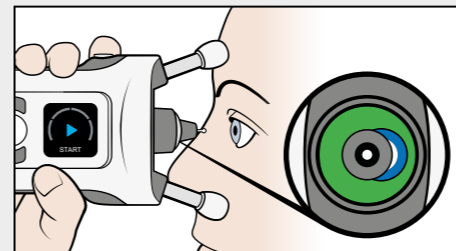
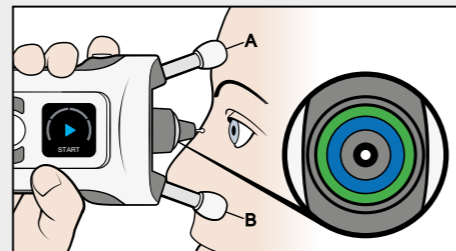
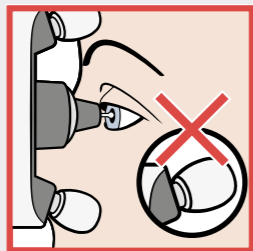
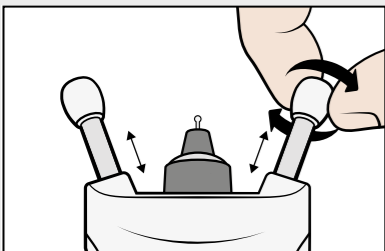

Ställ in rätt längd på pann- och kindstöden innan du börjar mäta. Börja med att dra ut stöden så långt det går.

Gör stöden kortare två klick i taget, inte mer, för att inte tonometern ska komma för nära ögat.

Håll tonometern mot ansiktet och titta in i sondbasen. Sonden pekar vinkelrätt mot mitten av ögat när de blåa och gröna cirkelarna i sondbasen är symmetriska.

Om cirkelarna inte är symmetriska betyder det att sonden inte pekar vinkelrätt mot mitten av ögat. Rätta till tonometerens position.

Håll båda ögonen öppna. Om du vill kan du täcka över det öga som inte mäts för att se cirkelarna tydligare.

Gör stöden kortare genom att rotera dem medsols, två klick i taget, tills du ser en, symmetrisk grön cirkel. Avståndet mellan tonometern och ögat är nu korrekt.



WARNING! Det är endast sonden som ska vidröra ögat. Låt inte ögat komma i kontakt med andra delar av tonometern. Peta dig inte i ögat med tonometern.

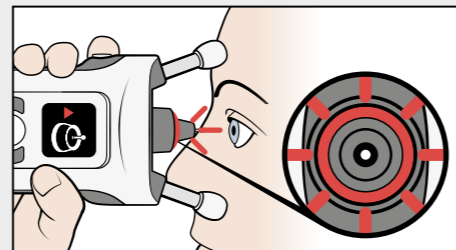
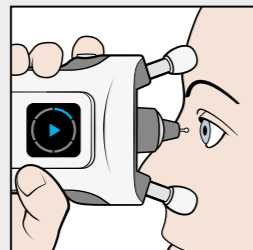
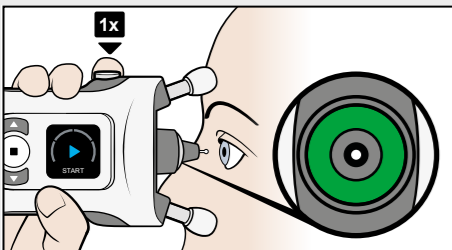

Mätningen kan börja när du ser en symmetrisk, grön cirkel. Tryck på Mät-knappen (▶) en gång. Sonden vidrör ögat lätt.

Ett enkelt pip ljud betyder att mätningen lyckades. Fortsätt och gör fler mätningar ända tills du hör ett långt pip ljud och ljuset i sondbasen släcks.

Om sondbasen blinkar rött och flera pip ljud hörs betyder det att något gick fel vid mätningen. Se **Felsökning** på sidan 52.

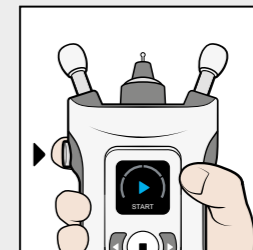
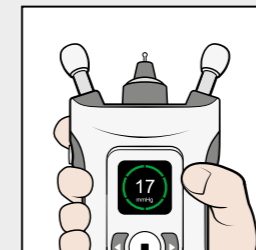
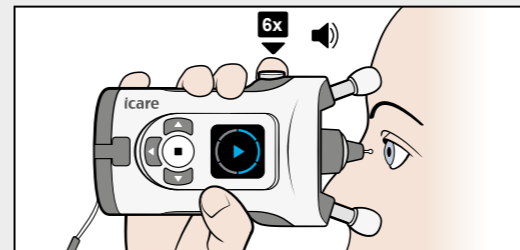

En mätsekvens består av sex mätningar.

Tips: Du kan även utföra en hel mätsekvens genom att trycka och hålla ner Mät-knappen (▶) ända tills alla sex mätningar har gjorts.

När sex mätningar har gjorts utan fel hörs ett längre pip ljud, ljuset i sondbasen släcks och resultatet visas på skärmen.

Tryck sedan på Mät-knappen (▶) en gång och gör om mätningarna på det andra ögat.

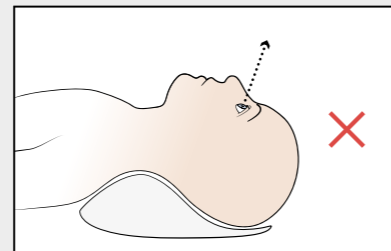
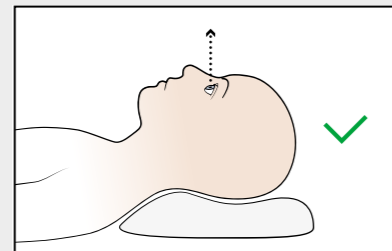
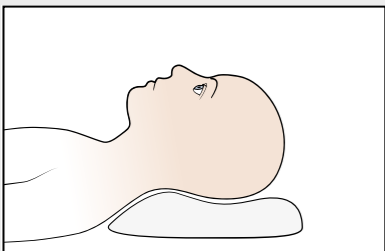

Lägg dig ner innan du börjar mäta.

Se till att du ligger bekvämt på rygg med en kudde bakom nacken. Titta rakt fram.

Undvik att böja huvudet bakåt.

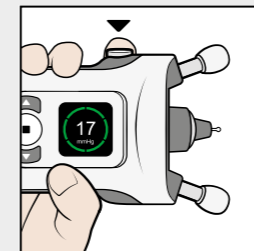
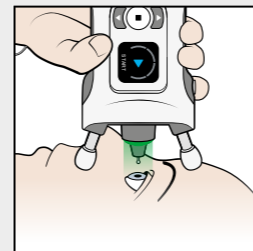





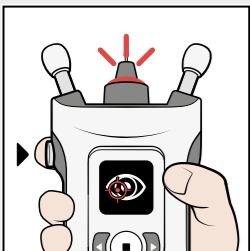



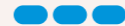

Håll tonometern i 90 graders vinkel mot ansiktet och gör mätningen enligt föregående beskrivning.

Efter att mätningen har avslutats utan fel, tryck på Mät-knappen (▶) en gång och gör om mätningarna på det andra ögat.



Om ett fel uppstår blinkar sondbasen rött. Texten på skärmen och ljudsignalerna anger orsaken till felet.

Kontrollera skärmen, tryck  en gång på Mät-knappen, gör de nödvändiga korrigeringarna och mät sedan igen.

Ikon	Skärmtext	Ljud	Problem	Lösning
	LÅNGTIFRÅN	3 långa 	Sonden är för långtifrån ögat.	Tryck på Mät-knappen  en gång för att bekräfta felet. Gör pann- och kindstöden kortare.
	NÄRA	5 korta 	Sonden är för nära ögat.	Tryck på Mät-knappen  en gång för att bekräfta felet. Gör pann- och kindstöden längre.
	FELAKTIG INRIKTNING	2 korta 	Sonden var inte vinkelrät mot hornhinnan eller vidrörde ögonlock eller ögonfransar.	Tryck på Mät-knappen  en gång för att bekräfta felet. Håll tonometern så att sonden pekar vinkelrätt mot mitten av ögat. Håll ögat helt öppet.
	UPPREPA	2 korta 	Problem med sondens rörelse.	Tryck på Mät-knappen  en gång för att bekräfta felet. Gör om mätningen.

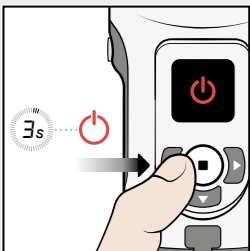

Tryck och håll ner Välj-knappen  tills du hör 3 pipjud och skärmen släcks.

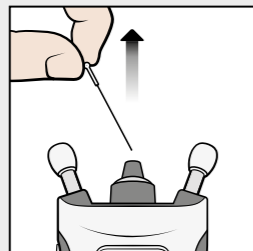

Ta ut sonden och lägg tillbaka den i sin behållare.



Kassera sonden och behållaren som blandavfall.

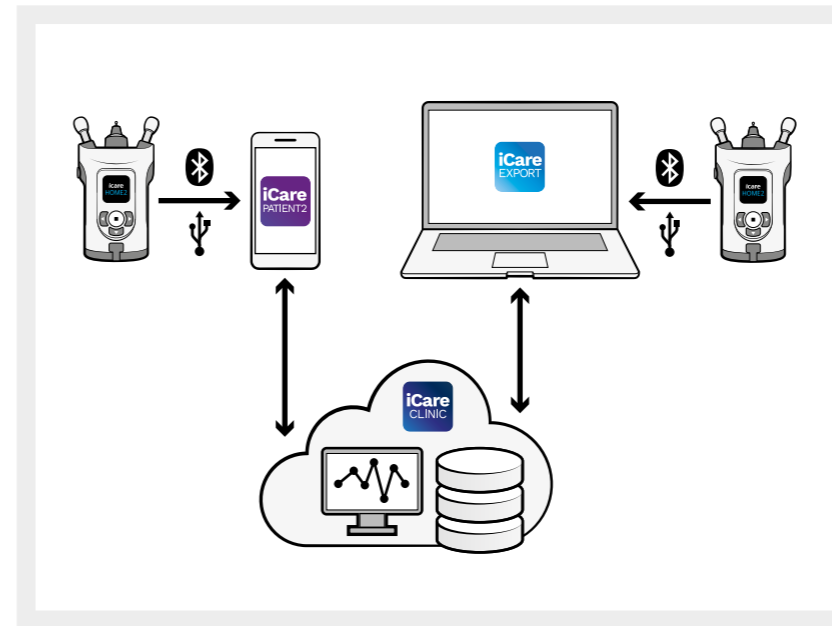

Nu kan du skicka mätresultaten till din läkares iCare CLINIC eller ditt eget konto på iCare Cloud med hjälp av appen iCare PATIENT2 på mobilen eller programmet iCare EXPORT på datorn.



Læs denne lynvejledning, og se videoen med HOME2 brugervejledninger, før du bruger tonometeret. Følg vejledningen trin for trin.



For sikkerhedsoplysninger skal du læse kapitel 1 i brugsvejledningen, før du bruger tonometeret.

Hvis du har brug for hjælp til at bruge iCare HOME2-tonometeret, skal du kontakte din læge.



SIKKERHEDSFORANSTALTNING! Inden du foretager målinger skal du opdatere tonometerets tid til din lokale tid manuelt fra tonometerets indstillinger eller automatisk ved at forbinde tonometeret til iCare PATIENT2-applikationen eller til iCare EXPORT-softwaren.



Dansk

Trin

Side

1	Isætning af batterier	59
2	Isætning af proben	60
3	Tænd	62
4	Korrekt måleposition	63
5	Justering af støtter og placering af tonometeret	64
6	Måling af trykket i øjet	66
7	Måling af øjentryk i liggende position	68
8	Fejlfinding	70
9	Slukning af tonometeret og bortskaffelse af proben	72

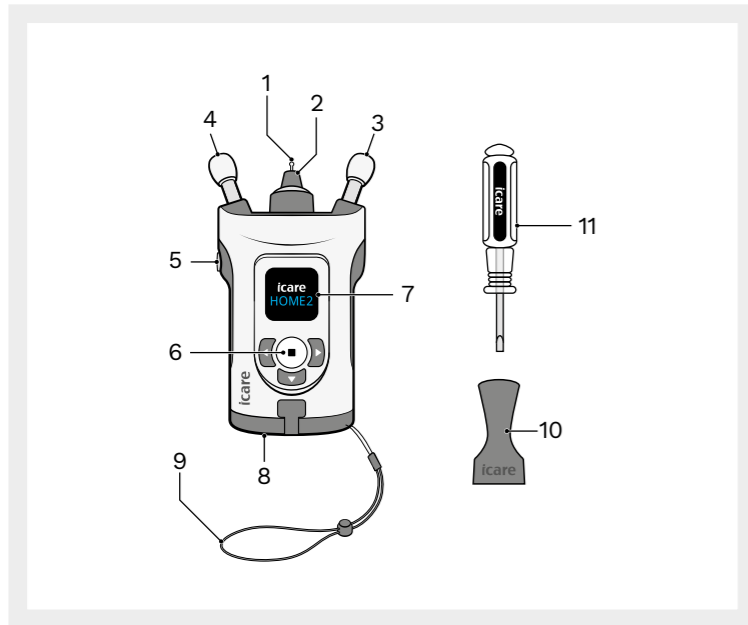

- 1 Probe
- 2 Probebase
- 3 Kindstøtte
- 4 Pandestøtte
- 5 Måleknap
- 6 Select knap
- 7 Display
- 8 Batteridæksel
- 9 Håndledsstrop
- 10 Probepåsatte
- 11 Skruetrækker

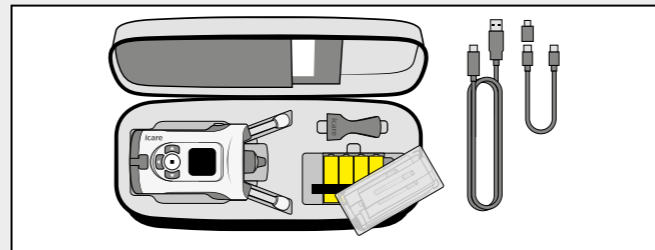

Batterierne ligger i tonometeret bæretaske under æsken med prober.

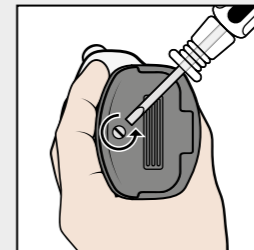

Åbn batteridækslet med skruetrækkeren.

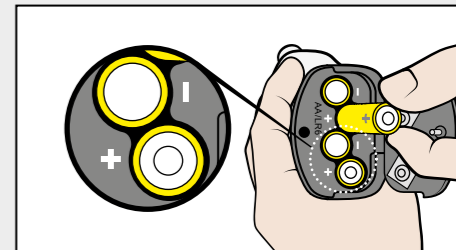

Sæt batterierne i, og luk dækslet.

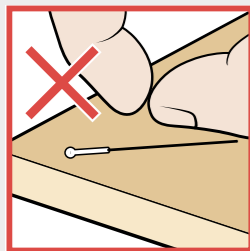

Brug ikke en probe, hvis den har rørt ved din hånd, et bord eller en anden ikke-steril overflade.

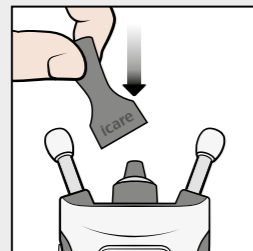

Placer probepå sætteren på tonometerbasen.

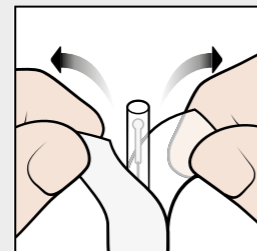

Åben pakken.

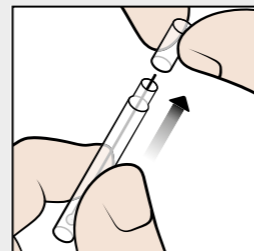

Fjern hættten.



ADVARSEL! For at undgå forurening skal ubrugte prober opbevares i æsken. Rør ikke ved en bar probe. Du må ikke bruge proben, hvis den kommer i kontakt med en ikke-steril overflade som et bord eller gulvet.

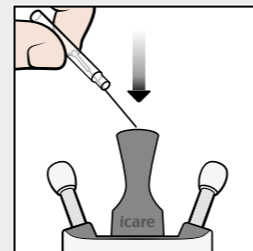

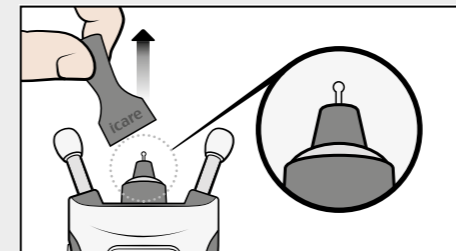

Lad proben glide fra beholderen ned i probepå sætteren.

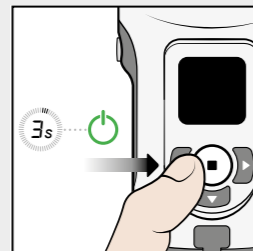
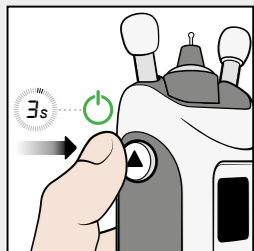

Fjern probepå sætteren.



Tryk  ned, indtil du hører et bip. Teksten "Start" vises på displayet.

Alternativt, tryk  ned, indtil du hører et bip. Tryk derefter på  igen for at gå ind i måletilstanden. Teksten "Start" vises på displayet.

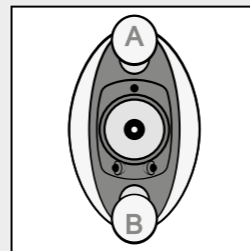

Pandestøtten A hviler på din pande og kindstøtten B hviler på din kind.

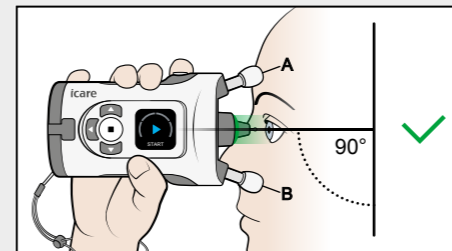

Se lige ud, med tonometeret i en 90-graders vinkel i forhold til dit ansigt. Proben er ca. 5 mm fra dit øje og peger vinkelret på midten af øjet.

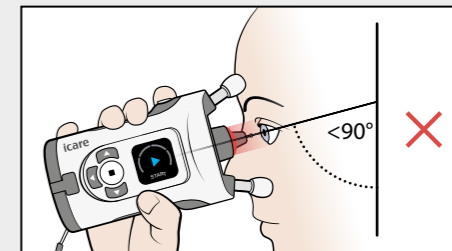

Hvis du ser et rødt lys i sondebasen, vippes tonometeret for meget nedad. Du bør rette din kropsholdning og løfte hagen.

Placering af tonometeret er anvist i det følgende afsnit.

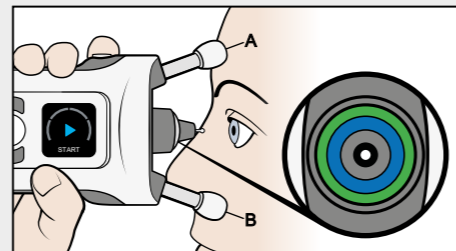
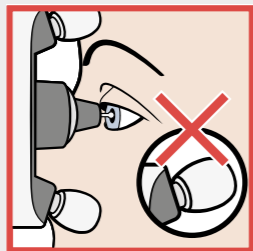
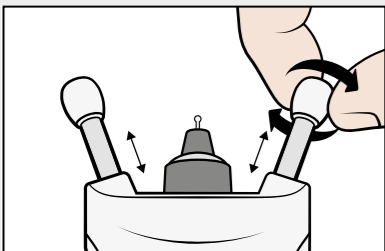

Før målingen justeres pande- og kindstøtterne til den korrekte længde. Start justeringen med støtterne på maksimal længde.

Forkort kun støtterne to klik ad gangen for at forhindre tonometeret i at komme for tæt på øjet.

Placer tonometeret mod ansigtet og kig ind i probebasen. Proben peger vinkelret ind på midten af øjet, når de blå og grønne ringe i probebasen er symmetriske.



ADVARSEL! Kun proben må røre øjet. Rør ikke ved øjet med andre dele af tonometeret. Stik ikke øjet med tonometeret.

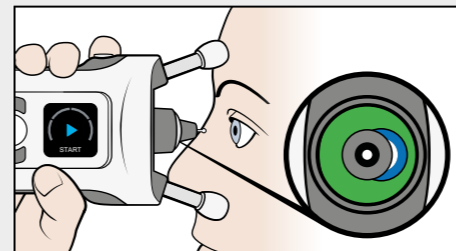

Hvis ringene ikke er symmetriske, peger proben ikke vinkelret ind på midten af øjet. Korrigér tonometerets position.

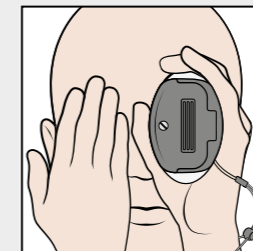

Hold begge øjne åbne. Dækning af det øje, der ikke bliver testet, kan hjælpe dig med at se ringene mere klart.

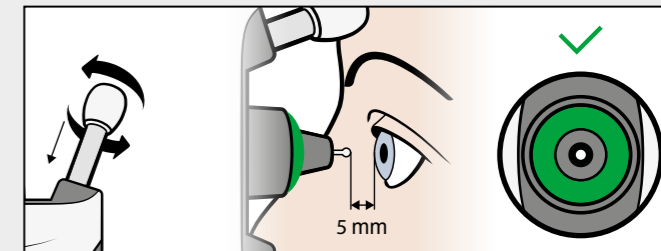

Forkort støtterne ved at dreje dem med uret to klik ad gangen, indtil du kun ser én symmetrisk grøn ring. Tonometeret er nu i den rigtige afstand fra øjet.

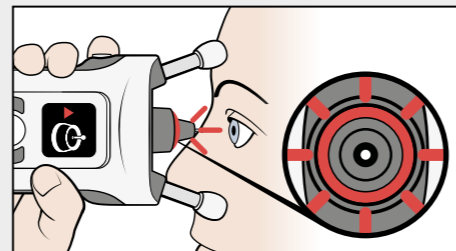
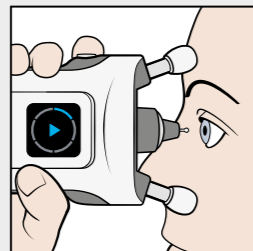
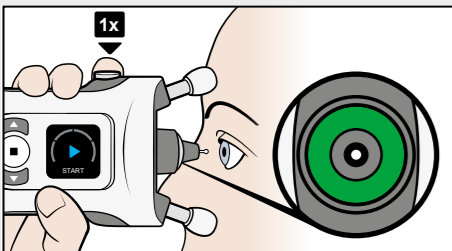

Start målingen, når du kun ser én symmetrisk grøn ring. Tryk på én gang på måleknappen (▶). Proben berører forsigtigt øjet.

Et enkelt bip betyder en vellykket måling. Fortsæt med at tage målinger, indtil du hører et langt bip, og lyset i probebasen slukkes.

Hvis probebasen blinker rødt, og du hører flere bip, lykkedes målingen ikke. Se **Fejlfinding** på side 70.

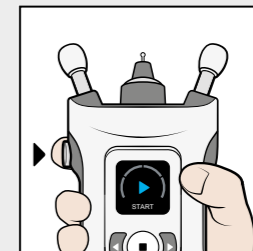
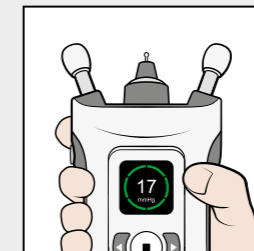
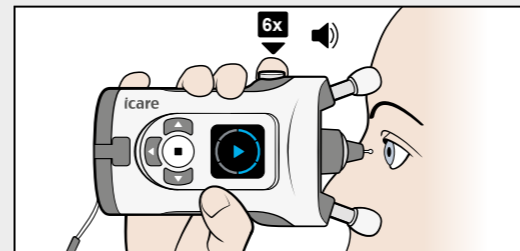

En målesekvens består af seks målinger.

Tip: Du kan også tage målesekvensen ved at trykke på og holde måleknappen (▶) nede, indtil alle seks målinger er foretaget.

Når alle seks målinger er taget, hører du et længere bip, lyset i probebasen slukkes, og du kan se resultatet på displayet.

Tryk én gang på måleknappen (▶), og gentag målingen på det andet øje.

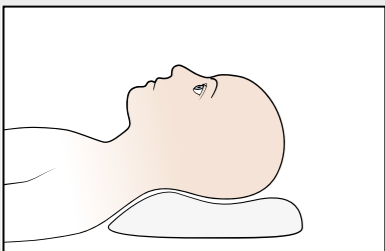

Lig ned et øjeblik inden målingen tages.

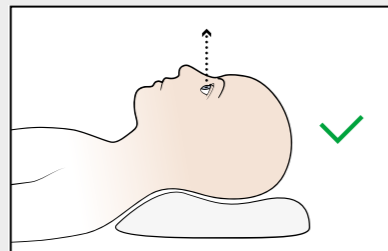

Indtag en behagelig position på ryggen med en pude bag nakken. Se lige ud.

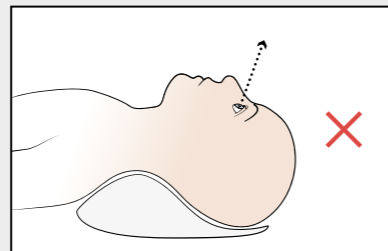

Undgå at bøje hovedet baglæns.

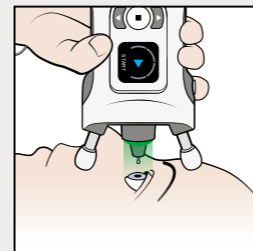

Placer tonometeret i en vinkel på 90 grader i forhold til dit ansigt og tag målingen som tidligere anvist.

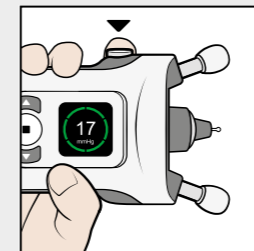



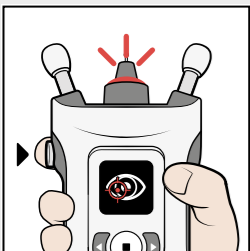









Efter en vellykket måling trykkes der én gang på måleknappen (▶), og målingen gentages på det andet øje.



Hvis der opstår en fejl, blinker probebasen rødt.
Displayet og lydene angiver kilden til fejlen.

Se på displayet, tryk på måleknappen  én gang,
foretag de nødvendige rettelser, og gentag målingen.

Ikon	Displaytekst	Lyd	Problem	Løsning
	FOR LANGT	3 lange 	Proben er for langt væk fra øjet.	Tryk én gang på måleknappen  for at bekræfte fejlen. Afkort støtterne til pande- og kind.
	FOR TÆT PÅ	5 korte 	Proben er for tæt på øjet.	Tryk én gang på måleknappen  for at bekræfte fejlen. Forlæng støtterne til pande- og kind.
	FORKERT JUSTERING	2 korte 	Proben var ikke vinkelret på hornhinden, eller den ramte et øjenlåg eller øjenvipper.	Tryk én gang på måleknappen  for at bekræfte fejlen. Placer tonometeret således at proben peger vinkelret på midten af dit øje. Hold dit øje ordentligt åbent.
	GENTAG	2 korte 	Der var et problem med probens bevægelse.	Tryk én gang på måleknappen  for at bekræfte fejlen. Gentag målingen.

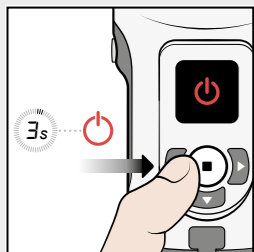

Tryk på og hold select-knappen  nede, indtil du hører tre bip, og displayet slukkes.

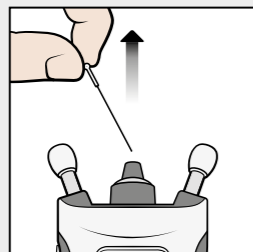

Fjern proben, og placer den tilbage i probebeholderen.



Kasser proben og beholderen bortskaffes i en affaldsspand til restaffald.

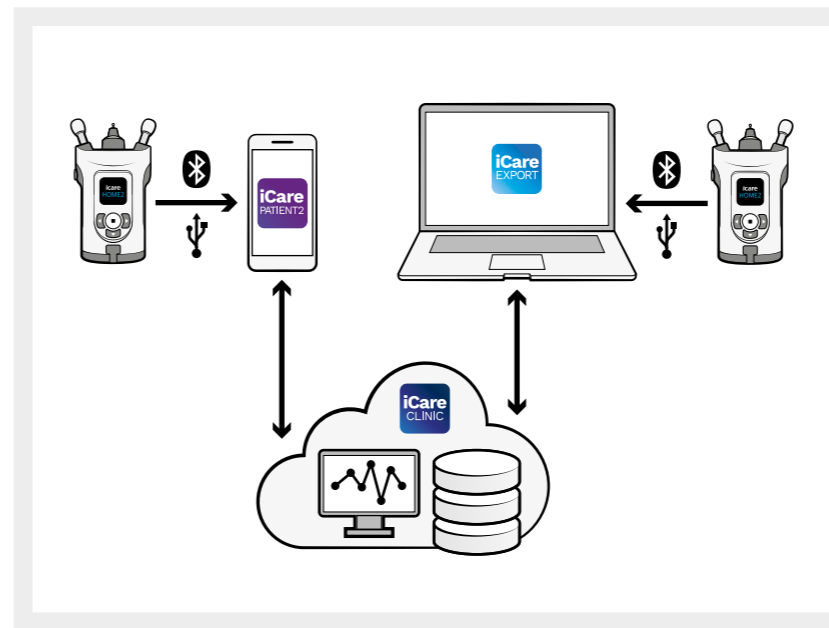

Nu kan du overføre dine måleresultater til din læges iCare CLINIC eller til din private konto i iCare Cloud ved hjælp af iCare PATIENT2-appen på din mobile enhed eller iCare EXPORT-softwaren på din computer.



Les gjennom denne hurtigveiledningen og se bruksanvisningsvideoen for HOME2 før du bruker tonometeret. Følg instruksjonene trinn for trinn.



Hvis du vil ha sikkerhetsinformasjon, se kapittel 1 i bruksanvisningen før du bruker tonometeret.

Hvis du trenger hjelp til å bruke iCare HOME2 tonometer, kan du kontakte helsepersonell.



FORHOLDSREGLER! Før du foretar målinger, må du oppdatere tonometerets tid manuelt til lokal tid i tonometerets innstillinger, eller automatisk ved å koble tonometeret til iCare PASIENT2-programmet eller iCare EXPORT-programvaren.



Norsk

Steg

Side

1	Innsetting av batterier	77
2	Sette inn proben	78
3	Aktivering	80
4	Korrekt måleposisjon	81
5	Justering av støtter og plassering av tonometeret	82
6	Måling av øyetrykk	84
7	Måling av øyetrykk i liggende stilling	86
8	Feilsøking	88
9	Avslåing av tonometeret og avhending av proben	90

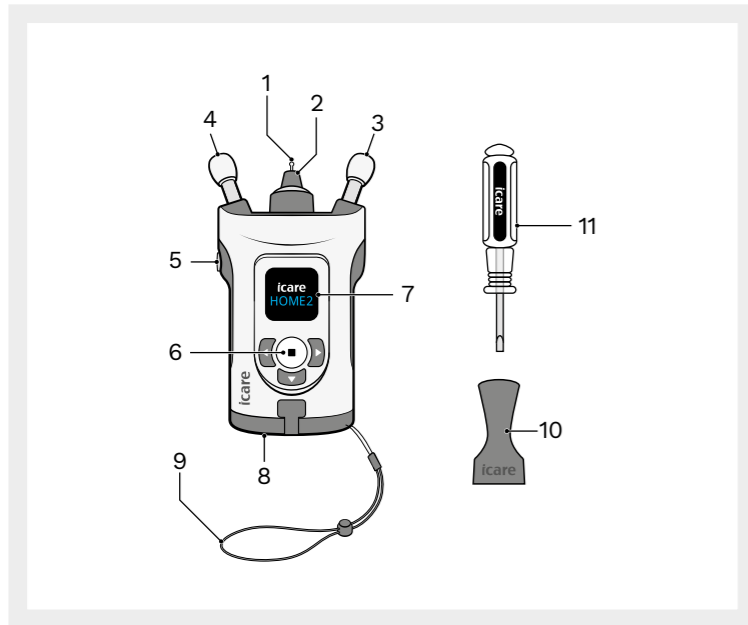

- 1 Probe
- 2 Probebase
- 3 Kinnstøtte
- 4 Pannestøtte
- 5 Måleknapp
- 6 Alternativknapp
- 7 Display
- 8 Batterideksel
- 9 Håndleddsstropp
- 10 Probeapplikator
- 11 Skrutrekker

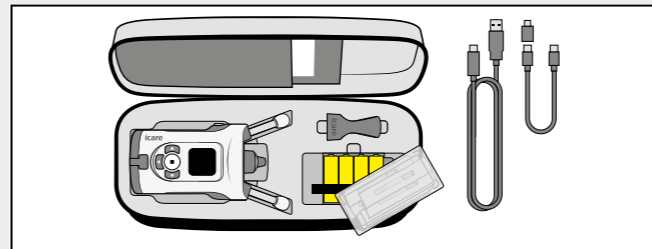

Batteriene ligger i tonometerets bæreseske under boksen med prober.

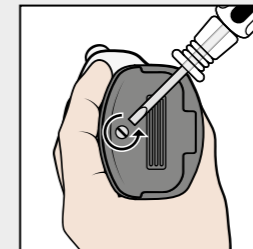

Åpne batteridekselet med skrutrekkeren.

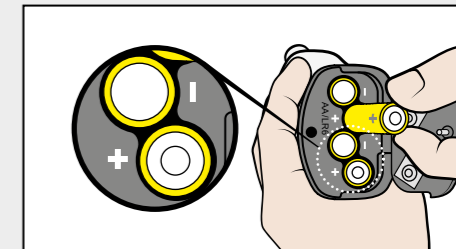

Sett inn batteriene, og lukk dekselet.

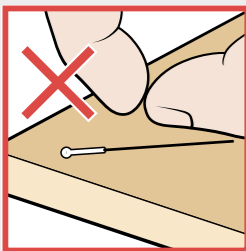

Ikke bruk en probe hvis den har vært borti hånden din, et bord eller en annen ikke-steril overflate.

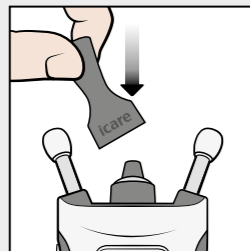

Plasser probe-applikatoren på probebasen.

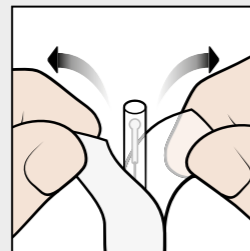

Åpne emballasjen.

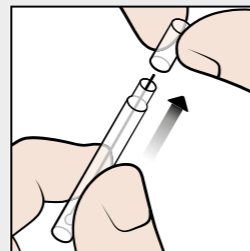

Fjern hetten.



ADVARSEL! For å unngå kontaminasjon, oppbevar ubrukte prober i esken. Ikke rør en åpen probe. Ikke bruk en probe hvis den berører en ikke-steril overflate, som for eksempel et bord eller et gulv.

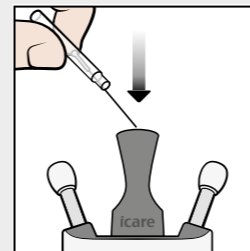

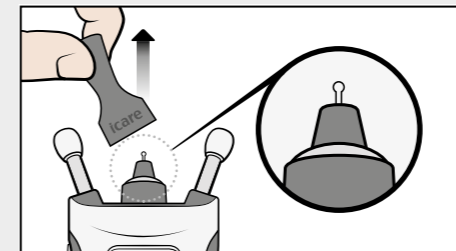

Slipp proben fra beholderen inn i probeapplikatoren.

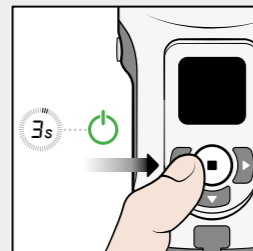
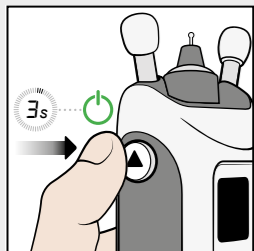

Fjern probeapplikatoren.



Trykk ned  til du hører et pip. Teksten "Start" vises på displayet.

Alternativt kan du trykke ned  til du hører et pip. Trykk deretter på  igjen for å gå inn i målemodus. Teksten "Start" vises på displayet.

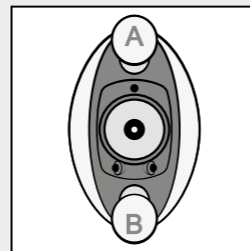

Pannestøtten A hviler på pannen og kinnstøtten B hviler på kinnet.

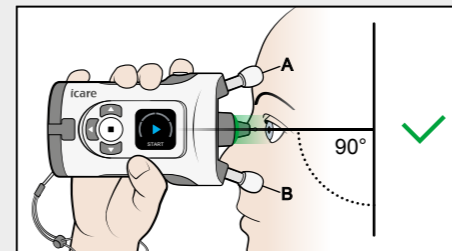

Se rett frem, tonometeret skal være i en 90-graders vinkel mot ansiktet ditt. Proben er ca. 5 mm fra øyet, og peker vinkelrett mot midten av øyet.

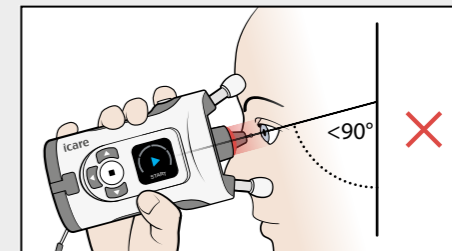

Hvis du ser et rødt lys i probebasen, er tonometeret vippet for mye nedover. Rett deg opp i ryggen, og løft haken.

Informasjon om plassering av tonometeret kommer i neste avsnitt.

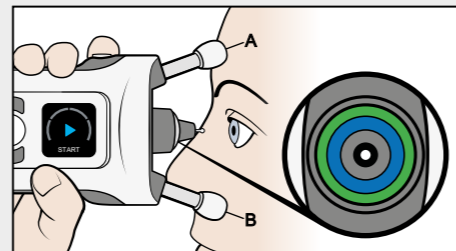
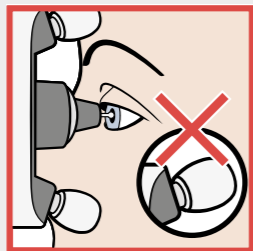
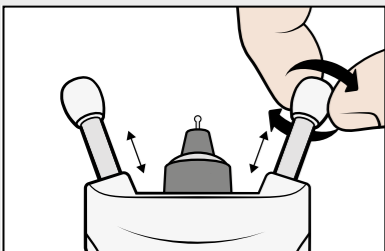

Før målingen, justerer du panne- og kinnstøttene til riktig lengde. Start justeringen med støttene på maksimal lengde.

Forkort støttene med bare to klikk om gangen for å hindre at tonometeret kommer for nær øyet.

Plasser tonometeret mot ansiktet ditt, og se inn i probebasen. Proben peker vinkelrett mot midten av øyet når de blå og grønne ringene i probebasen er symmetriske.



ADVARSEL! Bare proben skal berøre øyet. Ikke rør øyet med andre deler av tonometeret. Ikke stikk deg i øyet med tonometeret.

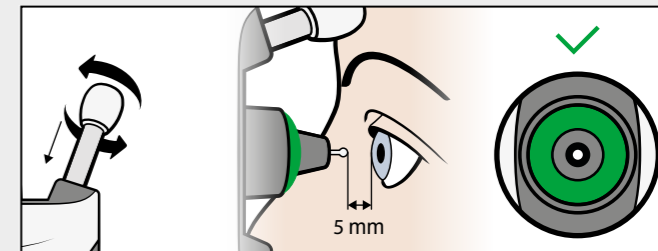
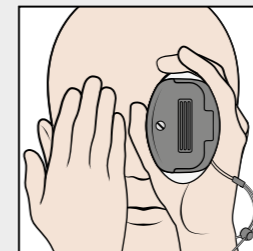
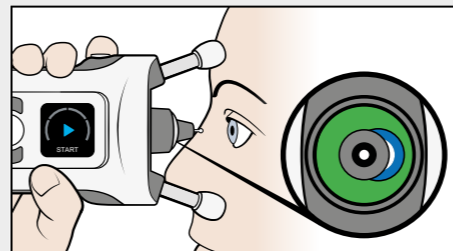

Hvis ringene ikke er symmetriske, betyr det at proben ikke peker vinkelrett mot midten av øyet. Korriger plasseringen av tonometeret.

Hold begge øynene åpne. Hvis du dekker til det øyet som ikke måles, kan det være lettere å se lysringene tydeligere.

Forkort støttene ved å rotere dem med klokken, to klikk om gangen til du bare ser en symmetrisk grønn ring. Tonometeret er nå i riktig avstand fra øyet.

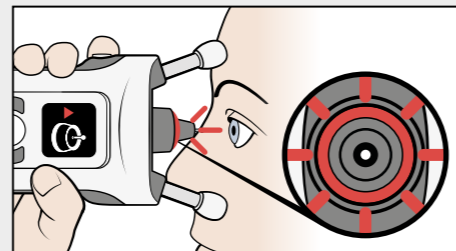
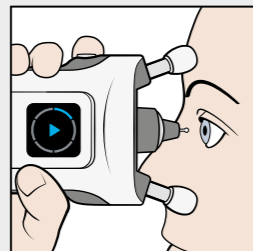
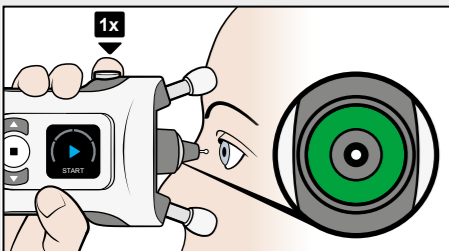

Start målingen når du bare ser en symmetrisk grønn ring. Trykk én gang på måleknappen (▶). Proben berører øyet ditt forsiktig.

Et enkelt pip betyr at målingen var vellykket. Fortsett å ta målinger til du hører et langt pip og lyset i probebasen slukkes.

Hvis probebasen blinker rødt og du hører flere pip, var målingen ikke vellykket. Se **Feilsøking** på side 88.

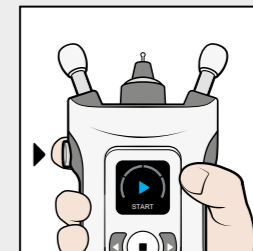
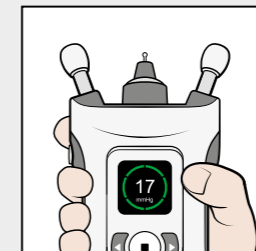
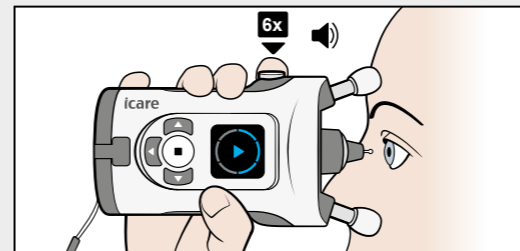

En målesekvens består av seks målinger.

Tips: Du kan også ta målesekvensen ved å trykke og holde Måleknappen (▶) nede til alle seks målingene er tatt.

Når alle seks målingene er tatt, hører du en lengre pipelyd, lyset i probebasen slukkes, og du ser resultatet på skjermen.

Trykk én gang på Måleknappen (▶), og gjenta målingen på det andre øyet.

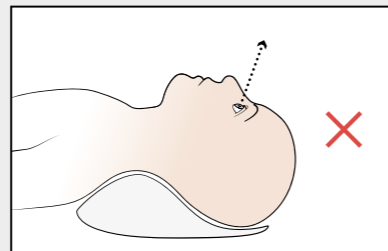
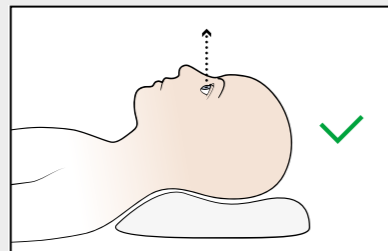
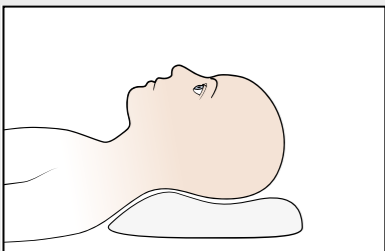

Legg deg ned et øyeblikk før du måler.

Ligg på ryggen i en komfortabel stilling med en pute bak nakken. Se rett frem.

Unngå å bøye hodet bakover.

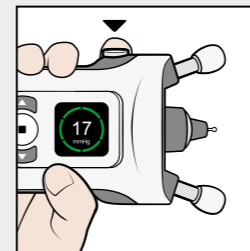
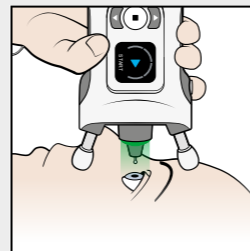





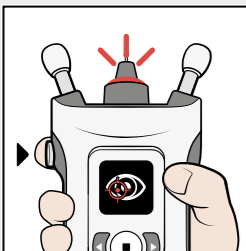







Plasser tonometeret i en 90 graders vinkel mot ansiktet ditt, og utfør målingen som tidligere anvist.

Etter en vellykket måling, trykker du én gang på Måleknappen (▶) og gjentar målingen på det andre øyet.



Hvis det oppstår en feil, blinker probebasen rødt. Displayet og lydene angir kilden til feilen.

Se på displayet, trykk én gang på Måleknappen , gjør de nødvendige korrigeringsene og gjenta målingen.

Ikon	Displaytekst	Lyd	Problem	Løsning
	FOR LANGT	3 lange 	Proben er for langt unna øyet.	Trykk på måleknappen  én gang for å bekrefte feilen. Forkort panne- og kinnstøttene.
	FOR NÆRE	5 korte 	Proben er for nærme øyet.	Trykk på måleknappen  én gang for å bekrefte feilen. Forleng panne- og kinnstøttene.
	FEIL ORIENTERING	2 korte 	Proben stod ikke vinkelrett mot hornhinnen, eller proben traff et øyelokk eller øyevipper.	Trykk på måleknappen  én gang for å bekrefte feilen. Plasser tonometeret slik at proben peker vinkelrett mot midten av øyet. Hold øyet helt åpent.
	GJENTA	2 korte 	Det var et problem med bevegelsen av proben.	Trykk på måleknappen  én gang for å bekrefte feilen. Gjenta målingen.

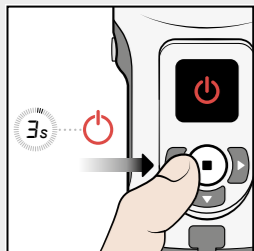

Trykk og hold inne Alternativknappen  til du hører 3 pip og displayet slukkes.

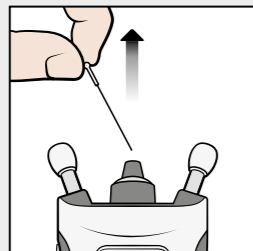

Fjern proben og sett den tilbake i probebeholderen.



Avhend proben og beholderen i en blandet avfallsbeholder.

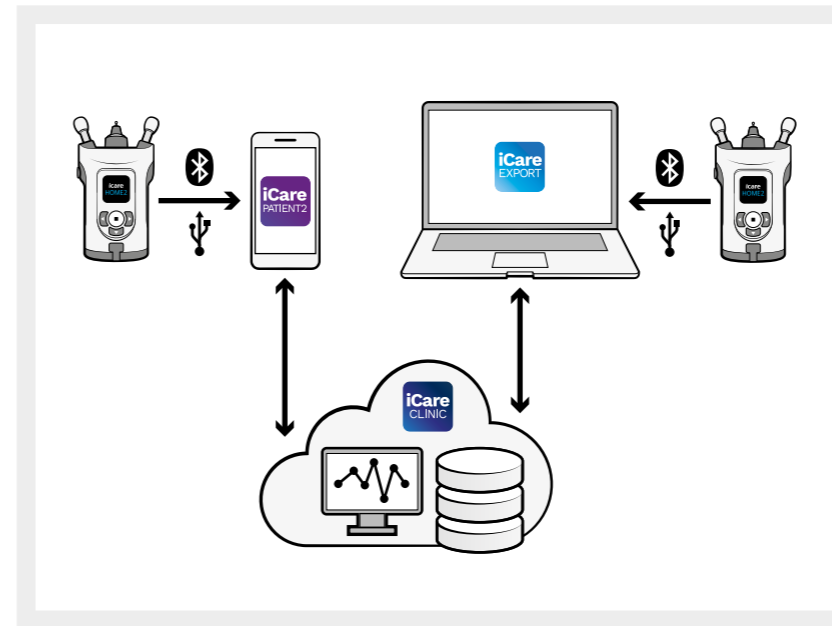

Nå kan du overføre måleresultatene dine til din leges iCare CLINIC eller til din private konto i iCare Cloud ved å bruke iCare PASIENT2-appen på din mobilenhet eller iCare EXPORT-programvaren på datamaskinen.



Διαβάστε αυτόν τον Γρήγορο Οδηγό και παρακολουθήστε το βίντεο οδηγιών χρήσης HOME2 πριν χρησιμοποιήσετε το τονόμετρο. Ακολουθήστε τις οδηγίες βήμα προς βήμα.



Για πληροφορίες σχετικά με την ασφάλεια, διαβάστε το Κεφάλαιο 1 του Εγχειριδίου Οδηγιών πριν χρησιμοποιήσετε το τονόμετρο.

Εάν χρειάζεστε βοήθεια για τη χρήση του τονόμετρου iCare HOME2, επικοινωνήστε με τον επαγγελματία υγείας σας.



ΠΡΟΦΥΛΑΞΗ! Πριν από τη λήψη μετρήσεων, ενημερώστε την ώρα του τονόμετρου στην τοπική ώρα σας χειροκίνητα από τις ρυθμίσεις του τονόμετρου ή αυτόματα συνδέοντας το τονόμετρο στην εφαρμογή iCare PATIENT2 ή στο λογισμικό iCare EXPORT.



Ελληνικά

Βήμα

Σελίδα

1	Τοποθέτηση των μπαταριών	95
2	Εισαγωγή του αισθητήρα	96
3	Ενεργοποίηση	98
4	Ορθή θέση μέτρησης	99
5	Ρύθμιση των βάσεων στήριξης και τοποθέτηση του τονόμετρου	100
6	Μέτρηση της πίεσης ματιών	102
7	Μέτρηση της πίεσης των ματιών σε ύπτια θέση	104
8	Αντιμέτωπιση προβλημάτων	106
9	Απενεργοποίηση του τονόμετρου και απόρριψη του αισθητήρα	108

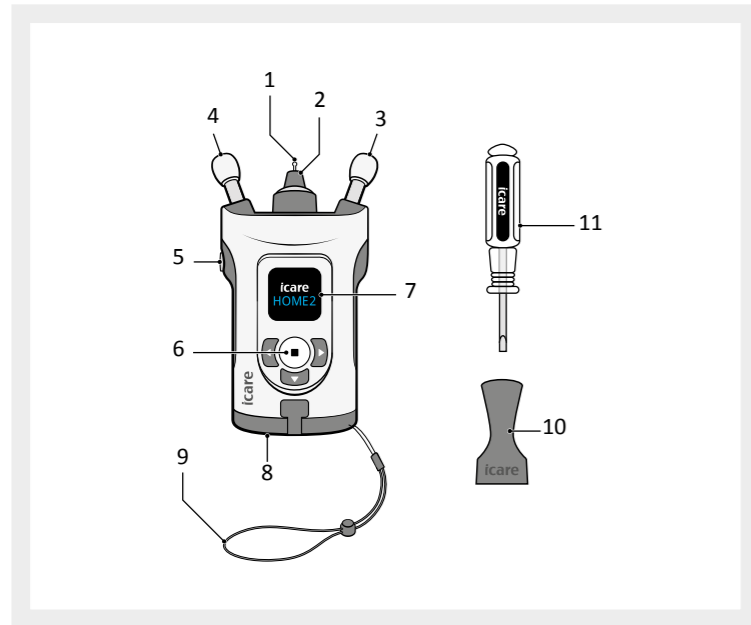

- 1 Αισθητήρας
- 2 Βάση αισθητήρα
- 3 Βάση στήριξης παρειών
- 4 Βάση στήριξης μετώπου
- 5 Κουμπί «Μέτρηση»
- 6 Κουμπί «Επιλογή»
- 7 Οθόνη
- 8 Κάλυμμα μπαταρίας
- 9 Λουράκι καρπού
- 10 Διάταξη εφαρμογής αισθητήρα
- 11 Κατσαβίδι

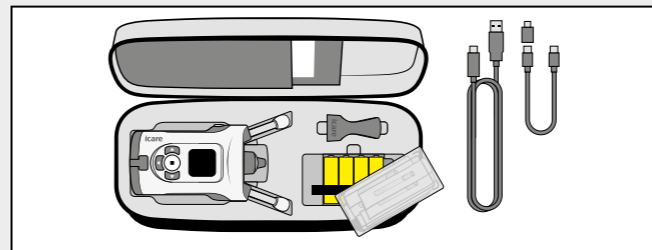

Οι μπαταρίες βρίσκονται στη θήκη μεταφοράς τονόμετρου κάτω από το κουτί αισθητήρων.

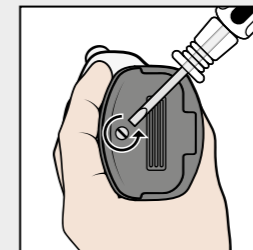

Ανοίξτε το κάλυμμα της μπαταρίας με το κατσαβίδι.

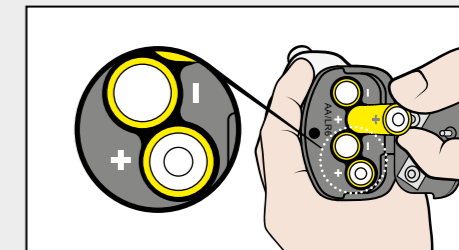

Τοποθετήστε τις μπαταρίες και κλείστε το κάλυμμα.

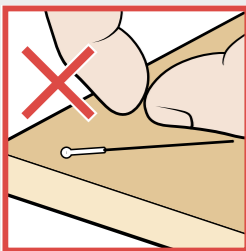

Μην χρησιμοποιείτε τον αισθητήρα, εάν έχει έρθει σε επαφή με το χέρι σας, τραπέζι ή άλλη μη αποστειρωμένη επιφάνεια.

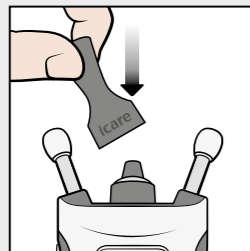

Τοποθετήστε τη διάταξη εφαρμογής αισθητήρα πάνω από τη βάση του αισθητήρα.

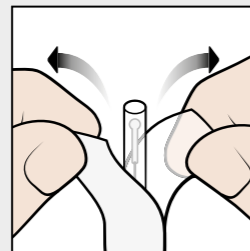

Ανοίξτε τη συσκευασία.

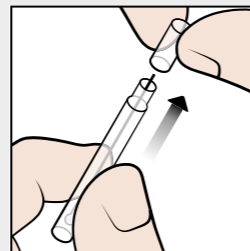

Αφαιρέστε το πώμα.



ΠΡΟΕΙΔΟΠΟΙΗΣΗ! Για την αποφυγή επιμόλυνσης, διατηρείτε τους αχρησιμοποίητους αισθητήρες στο κουτί τους. Μην αγγίζετε έναν γυμνό αισθητήρα. Μην χρησιμοποιείτε τον αισθητήρα, εάν έχει έρθει σε επαφή με μη αποστειρωμένη επιφάνεια, όπως τραπέζι ή δάπεδο.

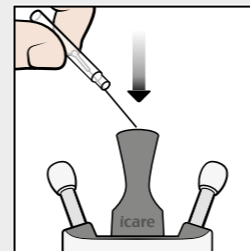

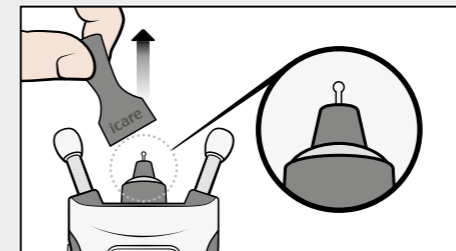

Τοποθετήστε τον αισθητήρα από το δοχείο στη διάταξη εφαρμογής αισθητήρα.

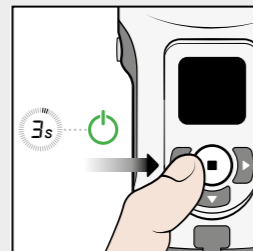
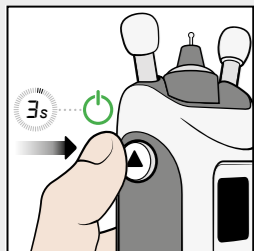

Αφαιρέστε τη διάταξη εφαρμογής αισθητήρα.



Πιέστε  έως ότου ακουστεί ο χαρακτηριστικός ήχος «μπιπ». Στην οθόνη εμφανίζεται η ένδειξη «Έναρξη».

Εναλλακτικά, πιέστε  μέχρι να ακούσετε τον χαρακτηριστικό ήχο «μπιπ». Στη συνέχεια, πιέστε  ξανά για να εισέλθετε στη λειτουργία μέτρησης. Στην οθόνη εμφανίζεται η ένδειξη «Έναρξη».

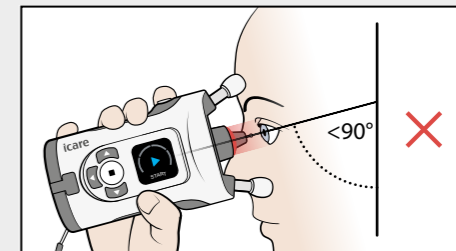
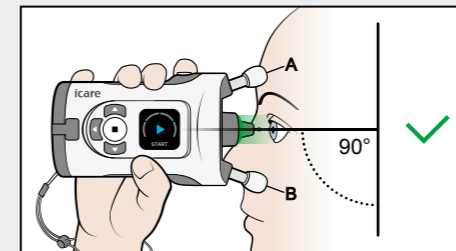
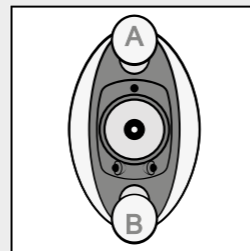

Η βάση στήριξης του μετώπου A τοποθετείται στο μέτωπό σας και η βάση στήριξης παρειών B τοποθετείται στο μάγουλό σας.

Εάν κοιτάξετε ευθεία μπροστά, το τονόμετρο βρίσκεται σε γωνία 90 μοιρών με το πρόσωπό σας. Ο αισθητήρας έχει απόσταση περίπου 5 mm από το μάτι σας και δείχνει κάθετα προς το κέντρο του ματιού σας.

Εάν βλέπετε ένα κόκκινο φως στη βάση του αισθητήρα, το τονόμετρο έχει υπερβολική κλίση προς τα κάτω. Θα πρέπει να ισιώσετε το σώμα σας και να σηκώσετε το πηγούνι σας.

Για την τοποθέτηση του τονόμετρου δίνονται οδηγίες στην επόμενη ενότητα.

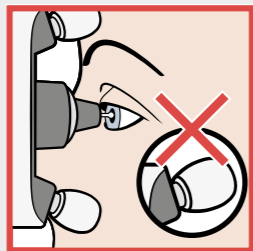
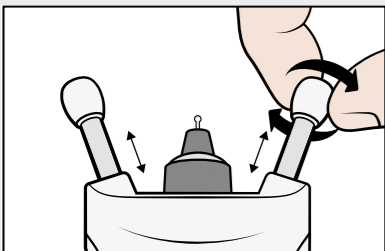

Κοντύνετε τις βάσεις στήριξης μόνο δύο κλικ τη φορά, προκειμένου το τονόμετρο να μην είναι πολύ κοντά στο μάτι σας.

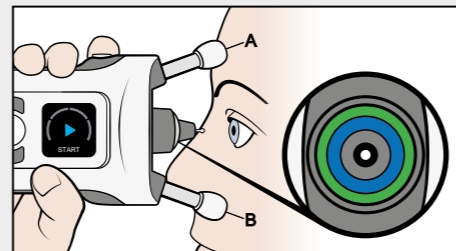

Τοποθετήστε το τονόμετρο στο πρόσωπό σας και κοιτάξτε στη βάση του αισθητήρα. Ο αισθητήρας δείχνει κάθετα προς το κέντρο του ματιού σας όταν ο μπλε και ο πράσινος δακτύλιος στη βάση του αισθητήρα είναι συμμετρικοί.

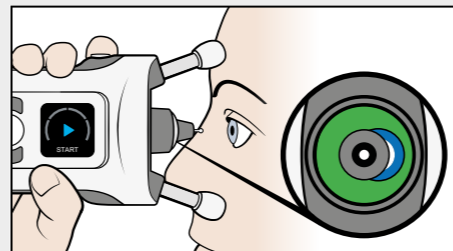

Εάν οι δακτύλιοι δεν είναι συμμετρικοί, ο αισθητήρας δεν δείχνει κάθετα προς το κέντρο του ματιού σας. Διορθώστε τη θέση του τονόμετρου.

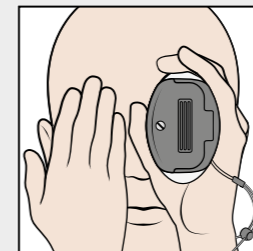

Κρατήστε και τα δύο μάτια ανοιχτά. Η κάλυψη του ματιού που δεν είναι προς εξέταση μπορεί να σας βοηθήσει στην καθαρότερη απεικόνιση των δακτυλίων.

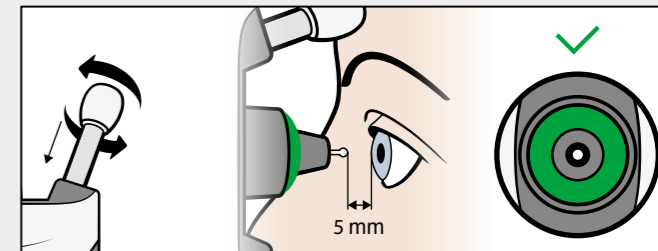

Κοντύνετε τις βάσεις στήριξης περιστρέφοντάς τις δεξιόστροφα κατά δύο κλικ τη φορά έως ότου βλέπετε μόνο έναν συμμετρικό πράσινο δακτύλιο. Το τονόμετρο είναι πλέον στη σωστή απόσταση από το μάτι σας.



ΠΡΟΕΙΔΟΠΟΙΗΣΗ! Μόνο ο αισθητήρας θα πρέπει να έρχεται σε επαφή με το μάτι. Το μάτι σας δεν πρέπει να έρχεται σε επαφή με άλλα μέρη του τονόμετρου. Μην πιέζετε το μάτι σας με το τονόμετρο.

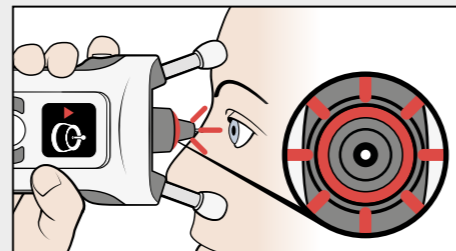
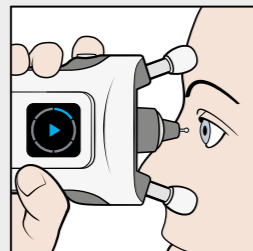
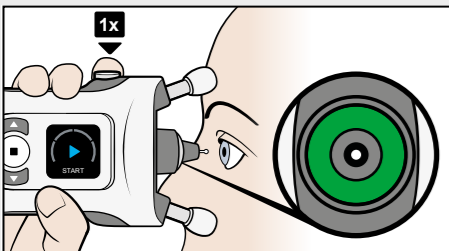

Ξεκινήστε τη μέτρηση όταν βλέπετε μόνο έναν συμμετρικό πράσινο δακτύλιο. Πατήστε το κουμπί «Μέτρηση» (▶) μία φορά. Ο αισθητήρας αγγίζει απαλά το μάτι σας.

Ένα ηχητικό σήμα υποδεικνύει μια επιτυχημένη μέτρηση. Συνεχίστε τις μετρήσεις έως ότου ακουστεί ένα συνεχές ηχητικό σήμα και το φως στη βάση του αισθητήρα σβήσει.

Εάν η βάση του αισθητήρα αναβοσβήνει με κόκκινο χρώμα και ακούσετε πολλαπλά ηχητικά σήματα, η μέτρηση δεν ήταν επιτυχής. Ανατρέξτε στην ενότητα **Αντιμετώπιση προβλημάτων** στη σελίδα 106.

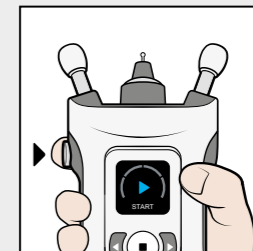
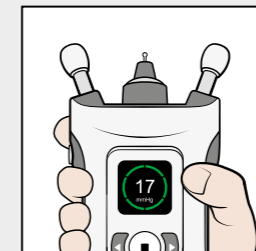
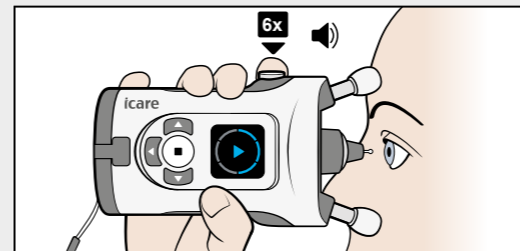

Μια ακολουθία μέτρησης αποτελείται από έξι μετρήσεις.

Υπόδειξη: Μπορείτε επίσης να πραγματοποιήσετε την ακολουθία μέτρησης πατώντας παρατεταμένα το κουμπί «Μέτρηση» (▶) έως ότου πραγματοποιηθούν και οι έξι μετρήσεις.

Όταν και οι έξι μετρήσεις έχουν ληφθεί με επιτυχία, θα ακουστεί ένα ηχητικό σήμα μεγαλύτερης διάρκειας, το φως στη βάση του αισθητήρα θα σβήσει και το αποτέλεσμα θα εμφανιστεί στην οθόνη.

Πατήστε το κουμπί «Μέτρηση» (▶) μία φορά και επαναλάβετε τη μέτρηση στο άλλο μάτι σας.

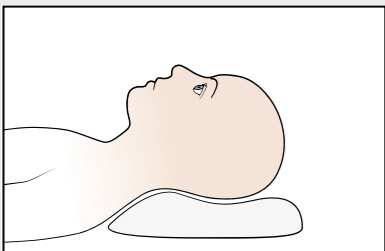

Πριν από τη μέτρηση, ξαπλώστε για λίγο.

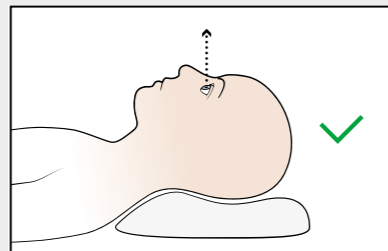

Ξαπλώστε άνετα σε ύπτια θέση με ένα μαξιλάρι πίσω από τον λαιμό σας. Κοιτάξτε ευθεία μπροστά.

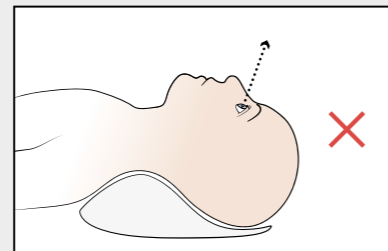

Μην γέρνετε το κεφάλι σας προς τα πίσω.

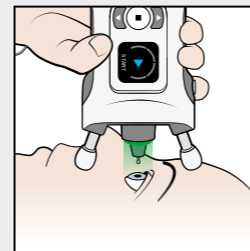

Τοποθετήστε το τονόμετρο σε γωνία 90 μοιρών με το πρόσωπό σας και πραγματοποιήστε τη μέτρηση σύμφωνα με τις προηγούμενες οδηγίες.

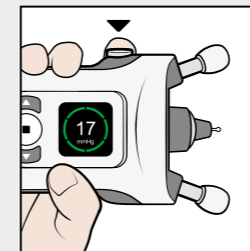



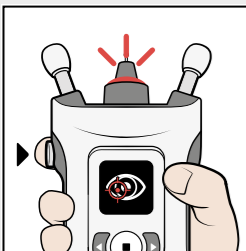









Μετά από μια επιτυχή μέτρηση, πατήστε το κουμπί «Μέτρηση»  μία φορά και επαναλάβετε τη μέτρηση στο άλλο μάτι σας.



Εάν παρουσιαστεί σφάλμα, η βάση του αισθητήρα αναβοσβήνει με κόκκινο χρώμα. Η οθόνη και οι ήχοι υποδεικνύουν την προέλευση του σφάλματος.

Κοιτάξτε στην οθόνη, πατήστε το κουμπί «Μέτρηση»  μία φορά, κάντε τις απαραίτητες διορθώσεις και επαναλάβετε τη μέτρηση.

Εικονίδιο	Ένδειξη οθόνης	Ήχος	Πρόβλημα	Επίλυση
	ΠΟΛΥ ΜΑΚΡΙΑ	3 μακρόσυρτοι 	Η απόσταση του αισθητήρα από το μάτι είναι πολύ μεγάλη.	Πατήστε το κουμπί «Μέτρηση»  μία φορά για να επιβεβαιώσετε το σφάλμα. Κοντύνετε τις βάσεις στήριξης μετώπου και παρειών.
	ΠΟΛΥ ΚΟΝΤΑ	5 σύντομοι 	Η απόσταση του αισθητήρα από το μάτι είναι πολύ μικρή.	Πατήστε το κουμπί «Μέτρηση»  μία φορά για να επιβεβαιώσετε το σφάλμα. Μακρύνετε τις βάσεις στήριξης μετώπου και παρειών.
	ΕΣΦΑΛΜΕΝΗ ΕΥΘΥΓΡΑΜ.	2 σύντομοι 	Ο αισθητήρας δεν ήταν κάθετος προς τον κερατοειδή ή ο αισθητήρας ήρθε σε επαφή με το βλέφαρο ή τις βλεφαρίδες.	Πατήστε το κουμπί «Μέτρηση»  μία φορά για να επιβεβαιώσετε το σφάλμα. Τοποθετήστε το τονόμετρο έτσι ώστε ο αισθητήρας να δείχνει κάθετα προς το κέντρο του ματιού σας. Διατηρείτε το μάτι σας κατάλληλα ανοιχτό.
	ΕΠΑΝΑΛΗΨΗ	2 σύντομοι 	Προέκυψε πρόβλημα με την κίνηση του αισθητήρα.	Πατήστε το κουμπί «Μέτρηση»  μία φορά για να επιβεβαιώσετε το σφάλμα. Επαναλάβετε τη μέτρηση.

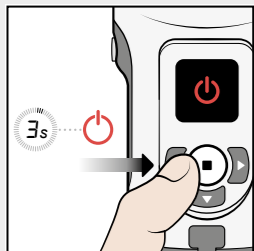

Πατήστε παρατεταμένα το κουμπί «Επιλογή»  μέχρι να ακούσετε 3 ηχητικά σήματα και να σβήσει η οθόνη.

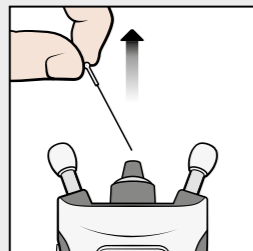

Αφαιρέστε τον αισθητήρα και τοποθετήστε τον ξανά στο δοχείο αισθητήρων.



Απορρίψτε τον αισθητήρα και το δοχείο σε κάδο μικτών απορριμμάτων.

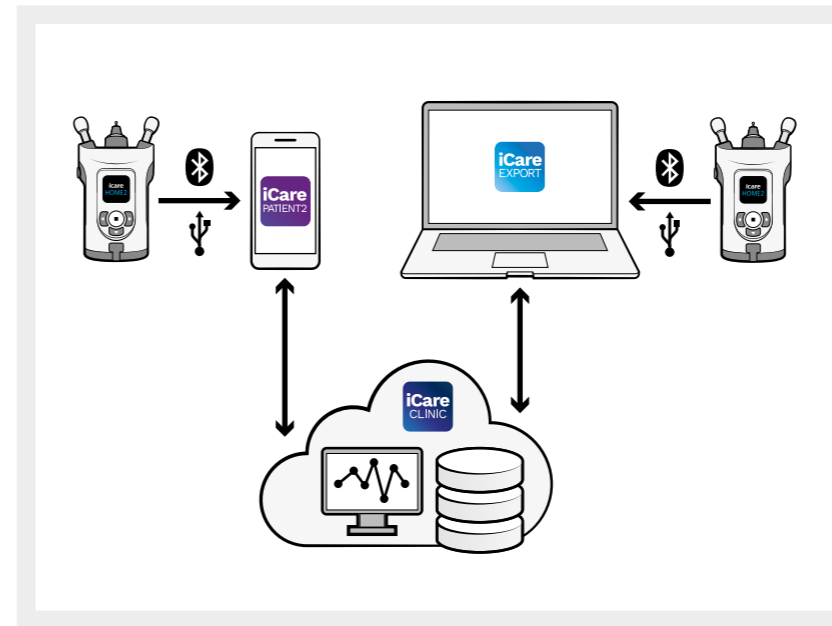

Τώρα μπορείτε να μεταφέρετε τα αποτελέσματα των μετρήσεων σας στο iCare CLINIC του γιατρού σας ή στον προσωπικό σας λογαριασμό στο iCare CLOUD χρησιμοποιώντας την εφαρμογή iCare PATIENT2 στην κινητή συσκευή σας ή το λογισμικό iCare EXPORT στον υπολογιστή σας.



Icare Finland Oy

Äyritie 22

01510 Vantaa, Finland

Ph. +358 9 8775 1150

info@icare-world.com



For further information,
read the instruction manual.



www.icare-world.com

icare

iCare is a registered trademark of Icare Finland Oy, Centervue S.p.A., Icare Finland Oy, and Icare USA Inc. are parts of Revenio Group and represent the brand iCare. Not all products, services or offers referenced in this brochure are approved or offered in every market and approved labeling and instructions may vary from one country to another. Product specifications are subject to change in design and scope of delivery and as a result of ongoing technical developments.